

STIMEX

Y&G

YOGA

AG

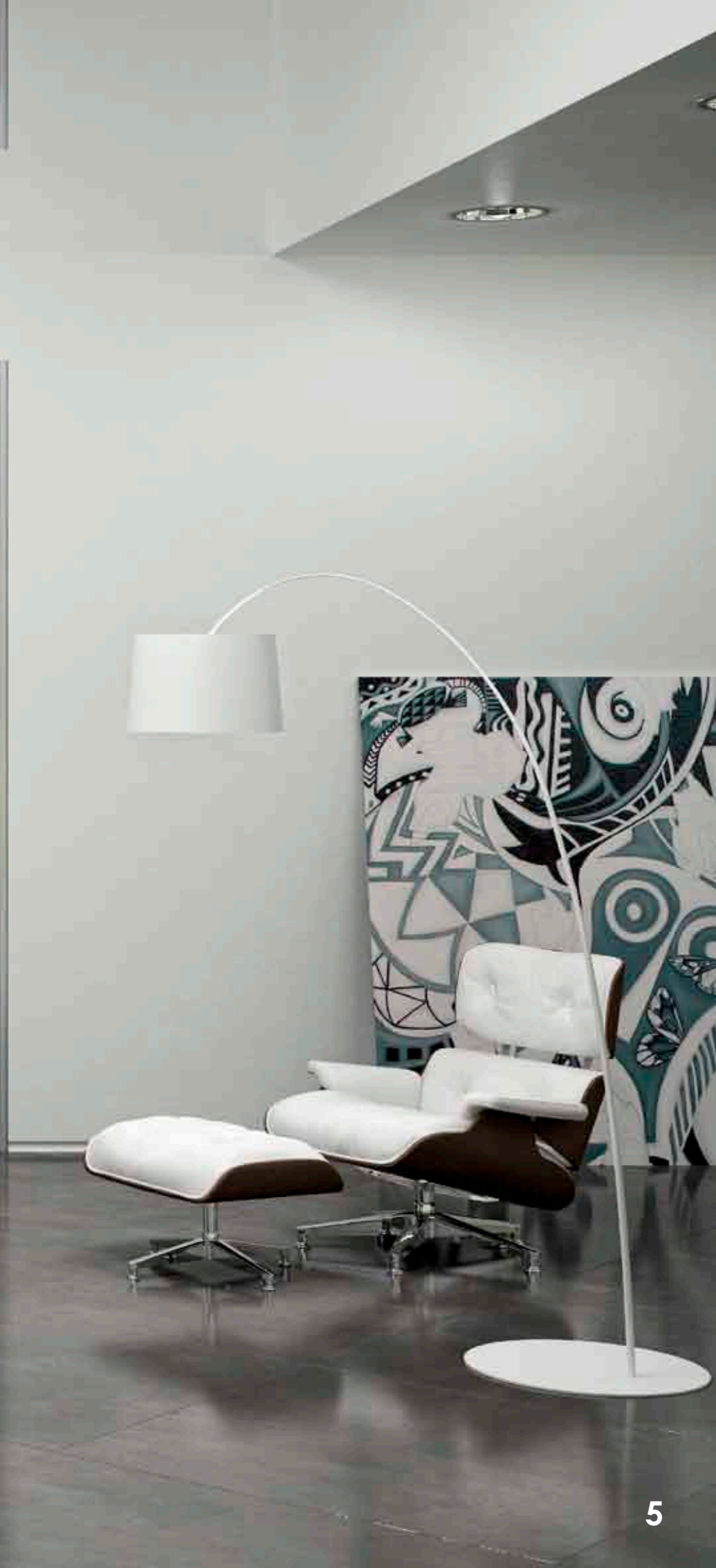







YOGA, UNA NUOVA DIMENSIONE DELLA CONTEMPORANEITÀ:

progetto di interiors definiti da forme essenziali e materiali ricercati. Ricerca di purezza e tattilità. Le nuove superfici in vetro no-print conferiscono una piacevole sensazione al tatto ed eliminano l'effetto impronta sui piani e sulle ante ad apertura push&pull.

Yoga, a new dimension of contemporaneity: An interiors project defined by essential shapes and elegant materials. Pursuit of purity and tactility. The new no-print glass surfaces give a pleasant feeling by touch and eliminate the imprint effect on push&pull surfaces and doors.

Yoga, une nouvelle dimension du contemporain : des conceptions d'intérieurs définies par des formes essentielles et des matériaux recyclés. Recherche de pureté et de tactilité. Les nouvelles surfaces en verre no-print confèrent une agréable sensation au toucher et éliminent les empreintes sur les plans et les portes à ouverture push&pull.







UNA PROPOSTA DALL'IMMAGINE HIGH-TECH:

volumi primari che definiscono una nuova geometria del contenere. I mobili pensili, che permettono un'infinita componibilità grazie agli elementi a giorno, ad anta e alle mensole con supporto a scomparsa.

A proposal coming from high-tech images: primary volumes, which define a new encompassing geometry. Wall units, which enable an endless unit furniture setting, thanks to the open elements, door units and shelves with concealed support.

Une proposition suggérant une image hautement technologique : des volumes primaires qui définissent une nouvelle géométrie du meuble. Les meubles suspendus permettant une modularité infinie grâce aux éléments ouverts ou avec porte et aux étagères avec support escamotable.





UNA COLLEZIONE IN CUI L'ORIGINALITÀ DEL DESIGN È AFFIANCATA DALLA VOLONTÀ

di formulare proposte in cui si incontrano essenze e metallo in una sintesi compositiva evoluta. La naturalezza del legno e la tecnicità del metallo si intersecano creando un layout compositivo naturale e di grande pregio.

A collection where the design novelty is backed by the will to formulate proposals in which fragrances and metal meet in an evolved constituent synthesis. The naturalness of wood and the technicity of metal criss-cross by creating a natural composition and high quality layout.

Une collection où l'originalité du design va de pair avec la volonté de formuler des propositions où les essences et le métal se rencontrent dans une synthèse de composition évoluée. La naturalité du bois et la technicité du métal s'entrecroisent en créant une composition naturelle et de haute qualité.





GRANDE ATTENZIONE PER I PARTICOLARI E PER GLI ACCESSORI

che semplificano ed agevolano lo svolgimento del lavoro. Tecnologia e funzionalità si integrano alle connessioni dei cablaggi e collegano il posto lavoro al mondo globale con una corretta gestione dei cavi.

Great attention for details and accessories that simplify and facilitate work development. Technology and practicality integrate with the wirings connections and connect the workplace to the global world with a correct management of cables.

Une attention spéciale aux détails et aux accessoires qui simplifient et facilitent l'exécution du travail. La technologie et la fonctionnalité se marient aux connexions des câblages et connectent le poste de travail au monde global suivant une gestion cohérente des câbles.





LAVORO SINGOLO O DI EQUIPE: SPAZI PER DECIDERE,

Lavoro singolo o di equipe: spazi per decidere, per aggregarsi, per consultarsi, per risolvere le necessità. Yoga ricerca armonia e risolve la componibilità dalla scrivania al grande tavolo riunione caratterizzato dal supporto canalizzato. Materiali e colori consentono di personalizzare il proprio spazio e creare l'equilibrio perfetto per ogni situazione.

Individual work or team work: spaces for decisions, aggregation, consulting and to solve needs. Yoga looks for harmony and solves the unite furniture setting from the desk to the large conference table characterized by the piped support. Materials and colours enable to customize one's own space and to create a perfect balance for every situation.

Travail individuel ou en équipe : des espaces pour décider, se rencontrer, se consulter, résoudre toute exigences. Yoga recherche l'harmonie et asservit la modularité du bureau à la grande table de réunion caractérisée par un support canalisé. Des matériaux et des couleurs permettant de personnaliser son espace personnel et de créer un équilibre parfait pour chaque situation.





POSTAZIONE "OPERATIVA" MULTIFUNZIONALE E NUCLEO CONVIVIALE

caratterizzato dal grande piano di lavoro che trova la negli elementi particolari , ante, cornici in alluminio, elementi verniciati, vetri extralight il proprio dettaglio caratterizzante. Gli elementi funzionali come i piedini regolabili, le maniglie, i passacavi creano un equilibrio nella massima coerenza stilistica.

Multifunctional "operating" position and convivial core characterized by a large worktop, which finds its own characterizing detail in the particular elements, doors, aluminium frames, varnished elements, extra-light glasses. The functional elements such as the adjustable feet, handles, fairleads create a balance in the utmost stylistic coherence.

Poste « opérationnel » multifonction et noyau convivial caractérisé par un grand plan de travail qui trouve dans les détails, les portes, les cadres en aluminium, les éléments peints, les vitres extra light, l'élément caractéristique de chacun. Les éléments fonctionnels comme les pieds réglables, les poignées, les passe-câbles créent un équilibre dans le maximum de cohérence stylistique.









LEGGEREZZA, ELEGANZA E MODULARITÀ,

un progetto ispirato al fascino della modernità e alla essenzialità della funzione. Lo scaffale libreria è declinato in una infinità di finiture e colori. La struttura in alluminio verniciato e le mensole in cristallo o nobilitato colorato si adattano ad ogni ambiente tra infiniti giochi di riflessi.

Lightness, elegance and modularity, a project inspired to the appeal of modernity and the essentiality of the function. The bookcase shelf is presented in an endless number of finishes and colours. The varnished aluminium structure and the crystal or faced wood shelves can suit every setting among an endless number of games and reflexes.

Légèreté, élégance et modularité, un projet s'inspirant du charme de la modernité et de la fonctionnalité essentielle. Le meuble bibliothèque est décliné dans une gamme infinie de couleurs et de finitions. La structure en aluminium peint et les étagères en cristal ou avec revêtement en bois coloré s'adaptent à tout intérieur entre des jeux de reflets infinis.











UN'INTERPRETAZIONE
DEL CLASSICO.
UNO SPAZIO CON LA
PROPRIA FUNZIONE,
L'AGGREGAZIONE.

L'essenzialità delle forme crea una naturale eleganza che predilige raffinati contrasti cromatici, nel valore della semplicità. L'accostamento dei piani di spessore minimo, la gamma di finiture e la leggerezza della struttura permette di creare infinite soluzioni per ogni tipo di gusto estetico.

An interpretation of the classical style. A space with its own function, the aggregation. The essentiality of shapes creates a natural elegance that prefers refined chromatic contrasts, in the value of simplicity. The matching of minimum thickness surfaces, the range of finishes and the lightness of the structure enable you to create endless solutions for every kind of taste.

Une interprétation du classique. Un espace avec sa propre fonction, l'agrégation. Les formes essentielles créent une élégance naturelle qui prime les contrastes chromatiques raffinés, dans la valeur de la simplicité. L'assemblage des plans d'une épaisseur minimale, la gamme de finitions et la légèreté de la structure permet de créer des solutions infinies pour répondre à tout type de goût esthétique.

GEOMETRIE PURE E DETTAGLI STILISTICI IN SOTTILE CONTINUITÀ CON IL PASSATO E LA TRADIZIONE.

Un'estetica dei contrari apparenti, di materia e trasparenza, in piena armonia. Più che un sistema Yoga è una partitura aperta, un catalogo di possibilità con cui progettare regole ed eccezioni. Ordine senza monotonia: materiali, finiture e componenti sono variazioni tematiche con cui comporre nello spazio il ritmo delle nostre giornate.

Pure geometries and stylistic details in a subtle continuity with the past and the tradition. A kind of appearance of apparent opposites, of matter and transparency, in full harmony. Rather than being a system, Yoga can be defined as an open score, a catalogue of opportunities by which it is possible to design rules and exceptions. Order without monotony: Materials, finishes and components are theme variations with which to make up the rhythm of our days in space.

Des géométries pures et des détails stylistiques dans une continuité subtile avec le passé et la tradition. Une esthétique des contraires apparents, de la matière et de la transparence, en pleine harmonie. Plus qu'un système Yoga est une partition ouverte, un catalogue de possibilités avec lequel projeter des règles et des exceptions. De l'ordre sans monotonie: matériaux, finitions et composants sont des variations thématiques avec lesquelles composer dans l'espace le rythme de nos journées.







CONTENITORI MA ANCHE SEMPlici RIPIANI APERTI E MODULI CHIUSI,

Contenitori ma anche semplici ripiani aperti e moduli chiusi, mensole e basi, consolle a muro, ma anche semplici tavoli circolari. Elementi per mostrare e per nascondere. Infinite declinazioni per sfruttare al meglio lo spazio grazie ad una completa gamma di composizioni che moltiplicano l'ecletticità del sistema.

Containers as well as simple open shelves and closed modules, shelves and bases, wall panels, as well as simple round tables. Elements to show and to hide. Endless declinations to exploit the space to the fullest, thanks to a complete range of compositions, which multiply the eclectic quality of the system.

Des meubles de rangement mais aussi de simples tablettes ouvertes et des modules fermés, des étagères et des bases, des consoles murales, mais aussi de simples tables circulaires. Des éléments pour montrer et pour cacher. Des possibilités infinies pour exploiter de la meilleure façon l'espace grâce à une gamme complète de compositions qui multiplient l'éclectisme du système.





FINITURE E SOLUZIONI TECNICHE IN PRIMO PIANO PER DARE IL GIUSTO RISALTO

al progetto globale della collezione. Dettagli di un sistema funzionale per risolvere la connessione del proprio posto lavoro con il mondo. Funzionalità e razionalità; tutti i componenti sono predisposti per alloggiare cablaggi e cavi di alimentazione. Gonne frontali, porta-cpu, gambe intermedia canalizzata per ogni esigenza particolare.

Finishes and technical solutions in close-up to accentuate the global project of the collection. Details of a functional system to solve the connection of one's workstation with the world. Functionality and rationality, all the components are prearranged to lodge wirings and feeder cables. Modesty panels, CPU holder, ducted intermediate legs for every special need.

Des définitions et des solutions techniques au premier plan pour faire ressortir de la meilleure façon possible le projet global de la collection. Les détails d'un système fonctionnel pour connecter son poste de travail au monde entier. Fonctionnalité et rationalité, tous les composants sont prévus pour loger des câblages et des câbles d'alimentation. Panneaux frontaux, porte-cpu, jambe intermédiaire canalisée pour toute exigence particulière.





IMPIALLACCIATI
WOOD VENEER
PLAQUÉS



i1NC Noce chiaro - Light Walnut
Noyer Clair



i1NS Noce scuro - Dark Walnut
Noyer Sombre

ESSENZE MELAMMINICHE
MELAMINE TYPES
ESSENCES MELAMINE



N3BD Bianco Dance - White Dance
Blanc Dance

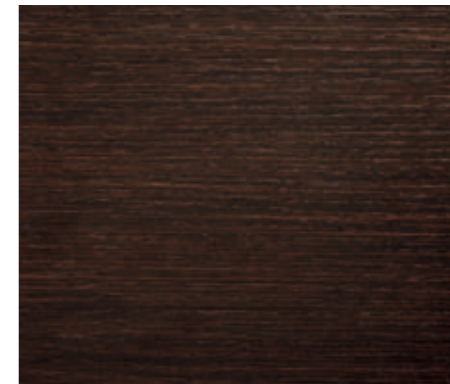

N2WE Wengè - Wenge
Wenge



N1NN Noce Naturale - Natural Walnut
Noyer Naturel



N3CB Ciliegio Blues - Cherry Blues
Cerise Blues

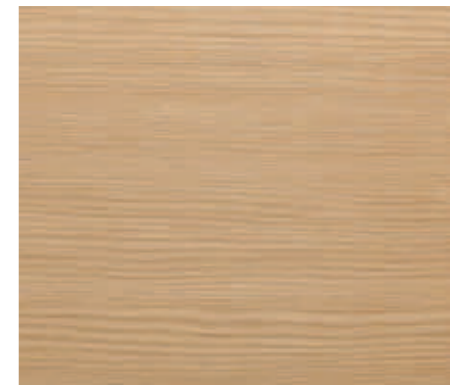

N3LG Larice - Larch Glam
Mélèze Glam



N3NS Noce Soul - Walnut Soul
Noyer Soul



N3RF Rovere Funk - Durmast Funk
Chêne Funk



N3RT Rovere Twist - Durmast Twist
Chêne Twist



N3NJ Nero Jazz - Black Jazz
Noir Jazz

LACCATI OPACHI
 MATT LACQUERED
 LAQUÉES MATES



L_BD Bianco Dance - White Dance
 Blanc Dance



L_GY Grigio Yoga - Grey Yoga
 Gris Yoga



L_NY Nero Yoga - Black Yoga
 Noir Yoga

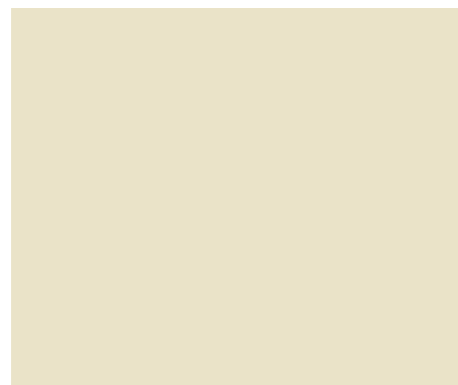

L_CR Cirpia Rosata - Rosy Face Powder
 Poudre Rose



L_SD Sabbia Desertica - Desert Sand
 Sable Du Désert



L_TS Tortora Selvatica - Wild Dove
 Tourterelle Sauvage



L_MC Melanzana Cruda - Raw Aubergine
 Aubergine Crue



L_RC Rosso Cardinale - Cardinal Red
 Rouge Cardinal



L_CL Cioccolato al latte - Milk Chocolate
 Chocolat au Lait



L_GS Grigio Scuro - Dark Grey
 Gris Sombre



L_RL Ral - Ral - Ral

VETRI
 GLASSES
 VERRES

LACCATI
 NO-PRINT
 NO-PRINT
 LACQUERED
 LAQUEES
 NO-PRINT



E3BD Bianco Dance - White Dance
 Blanc Dance

LACCATI
 LACQUERED
 LAQUEES



E1BD Bianco Dance - White Dance
 Blanc Dance

TRASPARENTI
 CLEAR
 TRANSPARENTES



E1EC Extrachiaro - Extra light
 Extra clair



E3GY Grigio Yoga - Grey Yoga
 Gris Yoga



E1GY Grigio Yoga - Grey Yoga
 Gris Yoga



E3VS Satinato - Satinated
 Satiné



E3NY Nero Yoga - Black Yoga
 Noir Yoga



E1NY Nero Yoga - Black Yoga
 Noir Yoga



V1GE Grigio Europeo - European Grey
 Gris Européen



E3RL Ral - Ral - Ral



E1RL Ral - Ral - Ral

GAMBE - GIUNTI - TRAVI
 LEGS - JOINTS - BEAMS
 PIÈTEMENTS - LIAISON - POUTRE



A1BD/A2BD Bianco Dance - White Dance
 Blanc Dance



A1GY/A2GY Grigio Yoga - Grey Yoga
 Gris Yoga



A1NY/A2NY Nero Yoga - Black Yoga
 Noir Yoga



A1CF Cromo Funky - Chrome Funky
 Chrome Funky



A2RL Ral - Ral - Ral

MANIGLIE
 HANDLES
 POIGNÉES

320mm



D912

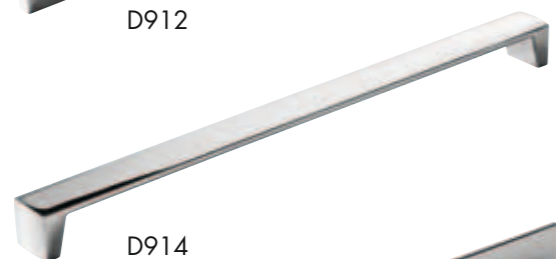

D914

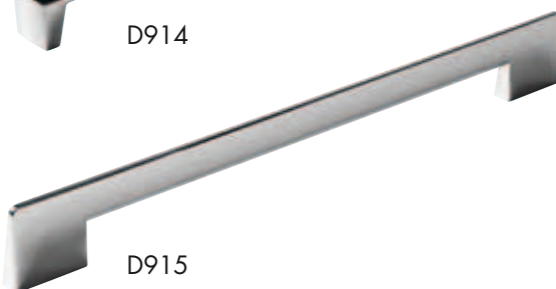

D915

160mm

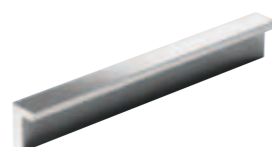

D902



D904

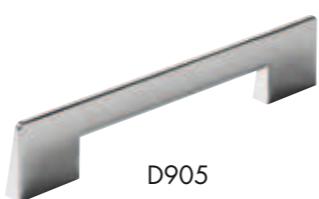

D905

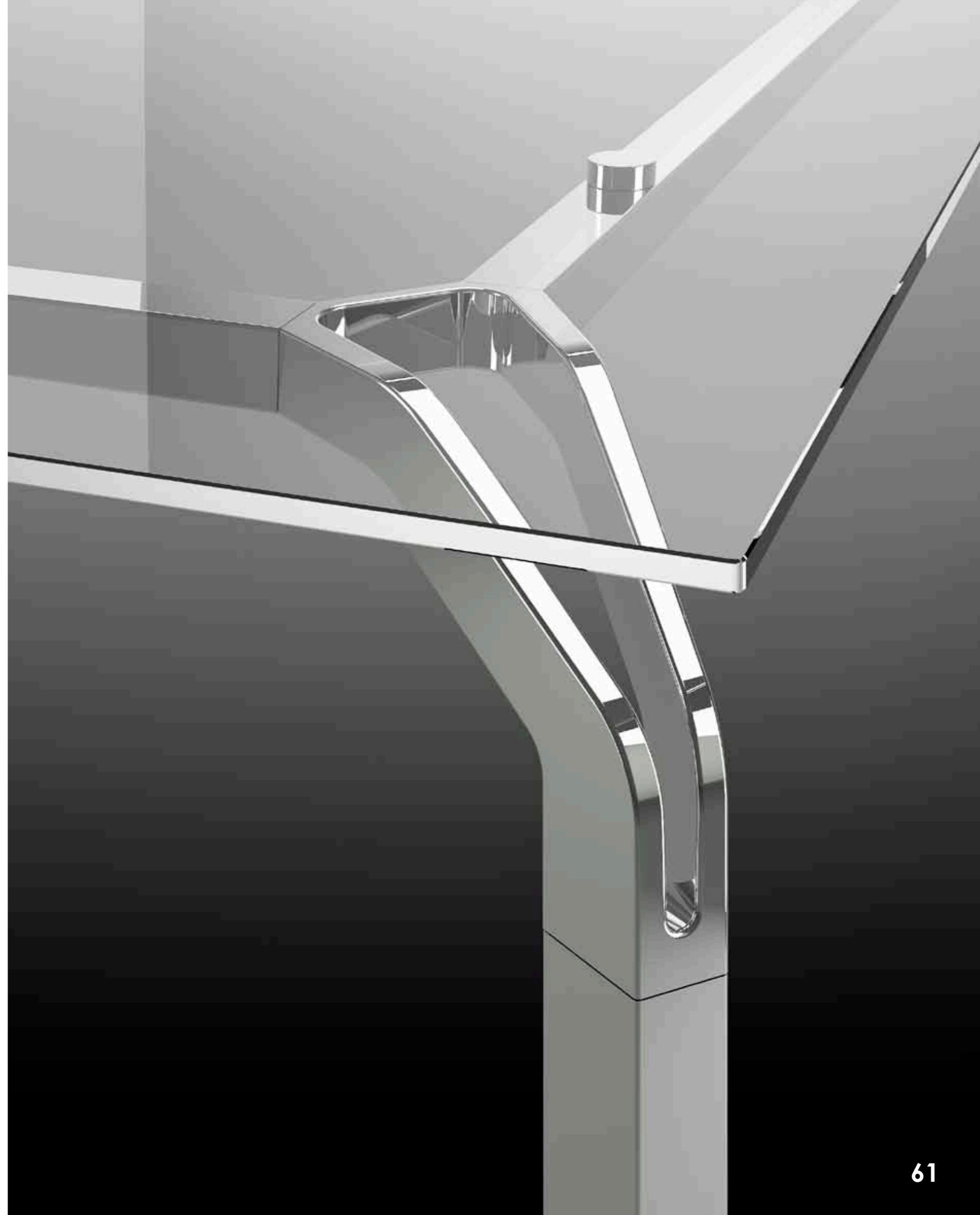

ABBINAMENTI CONSIGLIATI GAMBA - GIUNTO

PER SCRIVANIE E TAVOLI CON PIANI ESSENZA, IMPIALLACCIATI, LACCATI ANTIGRAFFIO, VETRO LACCATO E VETRO NO PRINT

SUGGESTED COMBINATIONS LEG - JOINT

FOR DESKS AND TABLES WITH WORKTOPS IN MFC TYPES, VENEER, SCRATCH RESISTANT LACQUERED, LACQUERED GLASS AND NO-PRINT GLASS

ASSORTIMENTS RECOMMANDÉS PIÈTEMENT - LIAISON

POUR BUREAUX ET TABLES AVEC PLANS EN MÉLAMINÉ, PLAQUÉS, LAQUÉS ANTI-RAYURE, VERRE LAQUÉ ET VERRE NO-PRINT

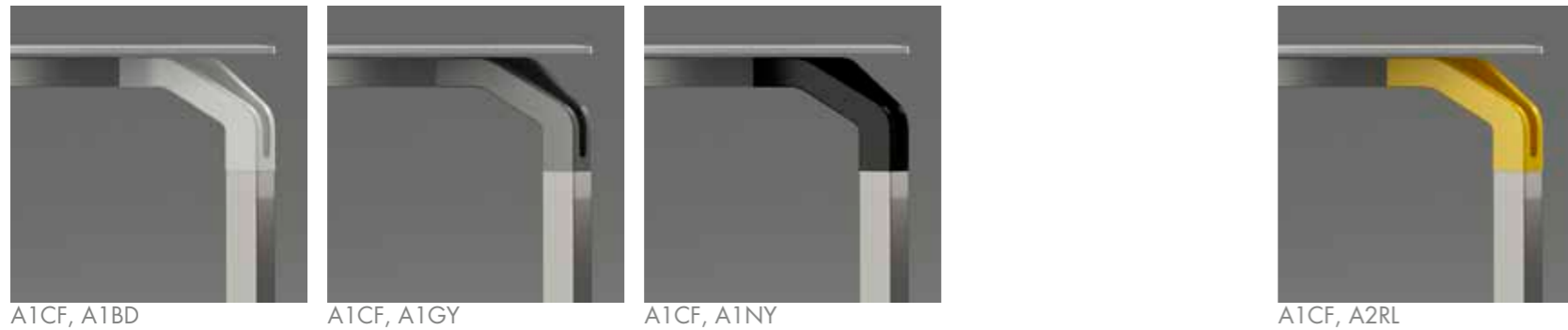
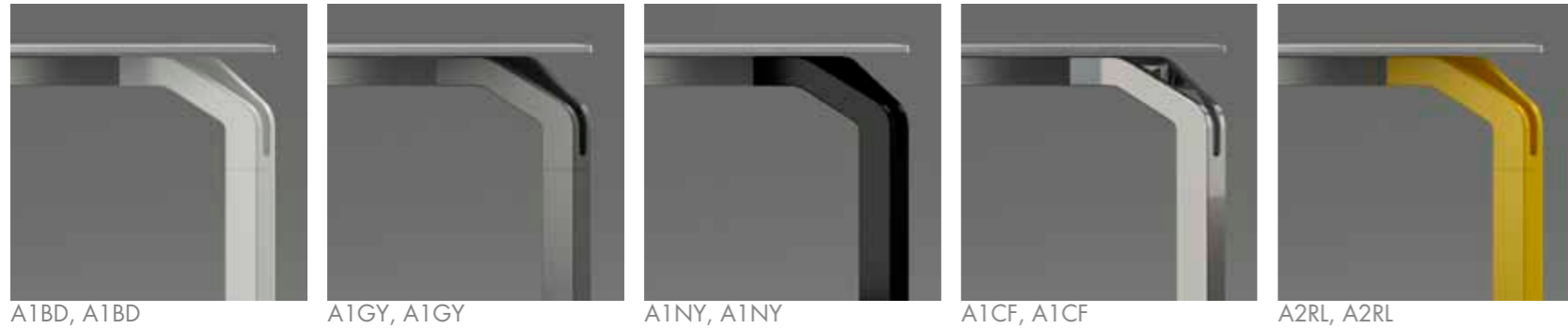

N.B.: IN QUESTI ABBINAMENTI PER I PIANI COPRENTI, LA TRAVE È NELLA FINITURA A1GY GRIGIO YOGA ED IL PIEDINO È SEMPRE CROMATO
NOTE: FOR THESE COMBINATIONS FOR BLIND WORKTOPS, THE BEAMS ARE ALWAYS IN FINISH A2GY YOGA GREY AND THE FEET ARE ALWAYS CHROME FINISH

ATTENTION: AVEC CES ASSORTIMENTS SI LES PLANS DE TRAVAIS NE SONT PAS TRASPARENTS, LA POUTRE EN FINITION A2GY GRIS YOGA ET LE PIED EST TOUJOURS CHROMÉ

ABBINAMENTI CONSIGLIATI GAMBA - GIUNTO - TRAVE

PER SCRIVANIE E TAVOLI CON PIANIVETRO TRASPARENTE

SUGGESTED COMBINATIONS LEG-JOINT-BEAM

FOR DESKS AND MEETING TABLES WITH WORKTOPS IN TRANSPARENT GLASS

ASSORTIMENTS RECOMMANDÉS PIÈTEMENT-LIAISON-POUTRE

POUR BUREAUX ET TABLES AVEC PLANS EN VERRE TRASPARENT

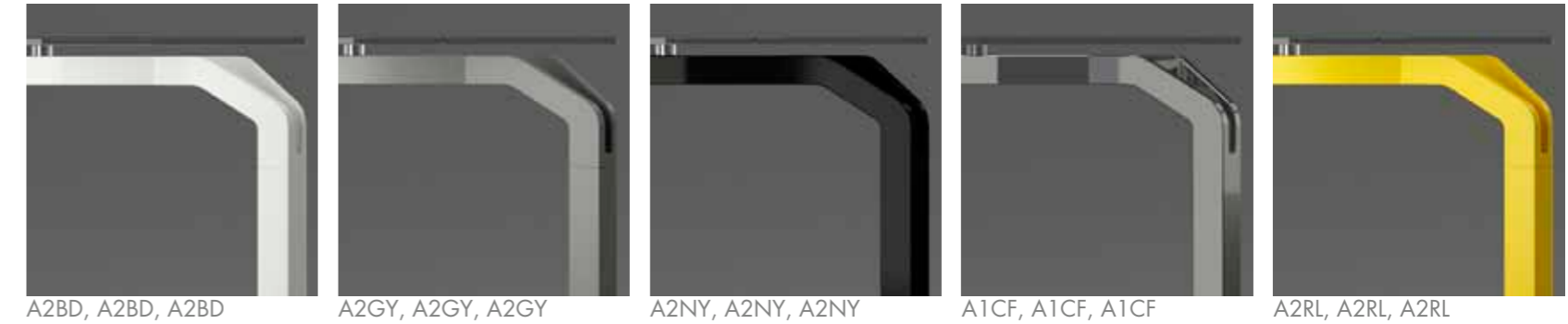

COMPONI YOGA:
CREATE YOUR YOGA:
FAITES VOS YOGA:

1 - SCEGLI LA GAMBA
CHOOSE LEG - CHOISIR PIÉTEMENT

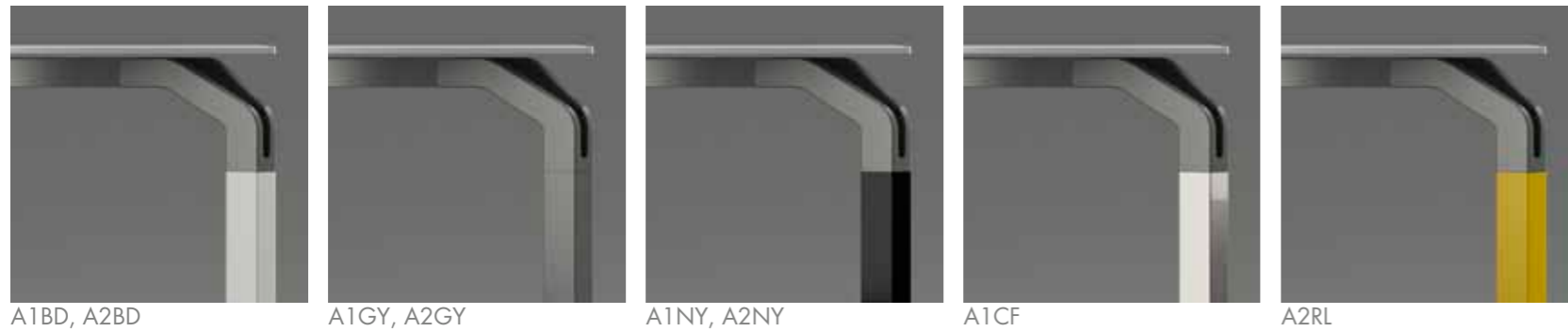

2 - SCEGLI IL GIUNTO
CHOOSE JOINT - CHOISIR LIAISON

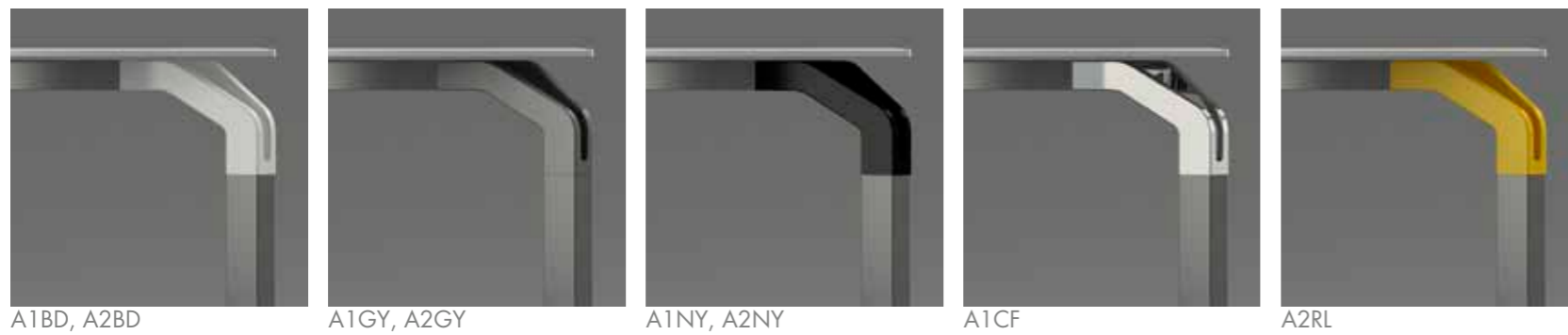

3 - SCEGLI LA TRAVE
CHOOSE BEAMS - CHOISIR POUTRE



4 - SCEGLI IL PIANO
CHOOSE WORKTOP - CHOISIR PLANS

IMPIALLACCIATI - WOOD VENEER - PLAQUÉS

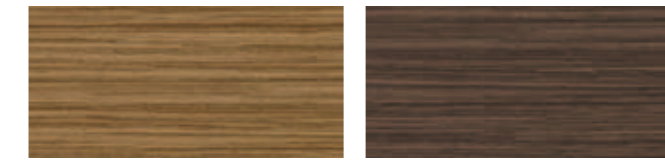

ESSENZE - TYPES - ESSENCES

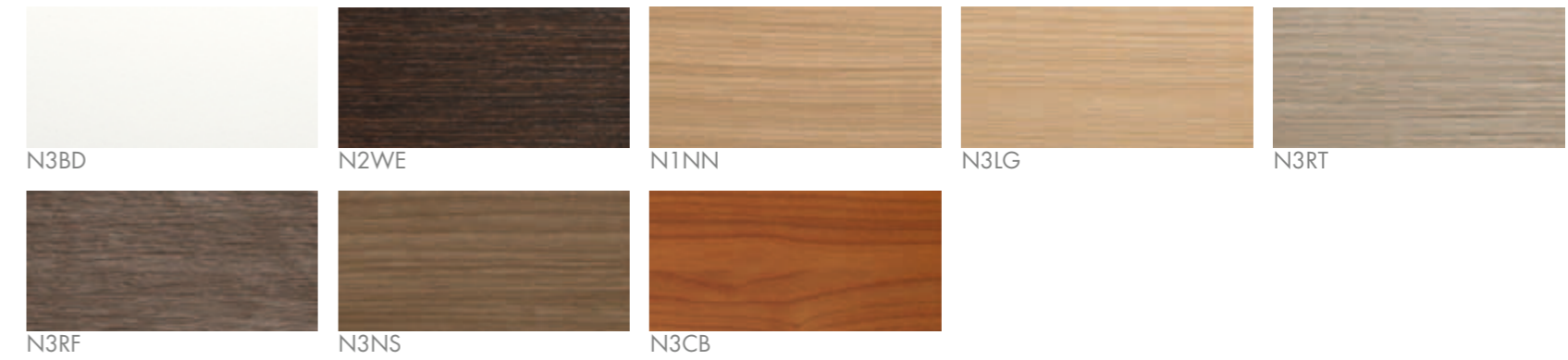

LACCATI - LACQUERED - LAQUÉES



VETRI LACCATI - LACQUERED GLASSES - VERRES LAQUÉES



VETRI LACCATI NO-PRINT - NO-PRINT LACQUERED GLASSES - VERRES LAQUÉES NO-PRINT

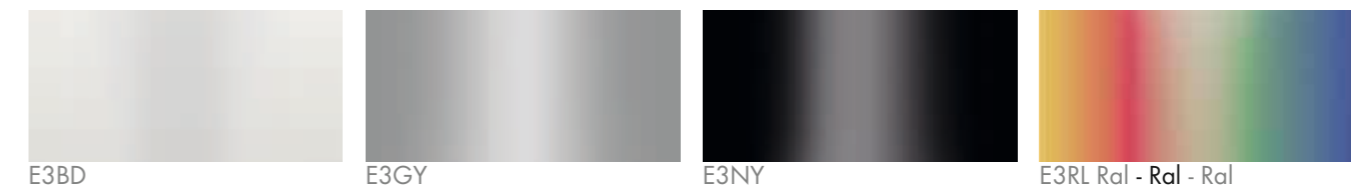

VETRI TRASPARENTI - CLEAR GLASSES - VERRES



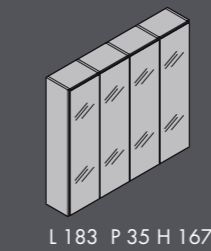
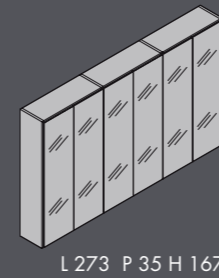
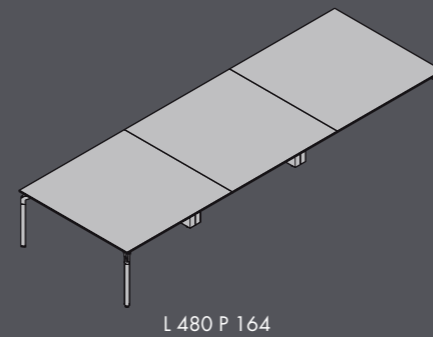
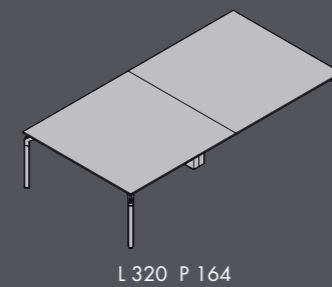
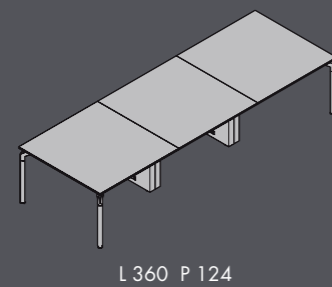
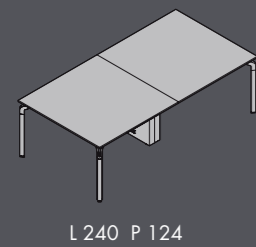
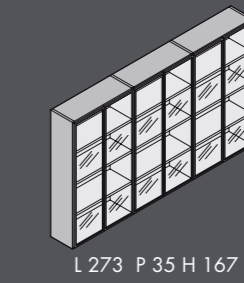
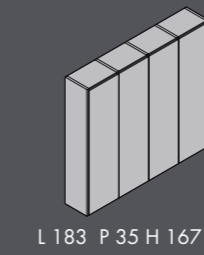
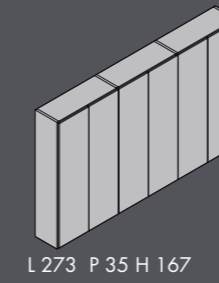
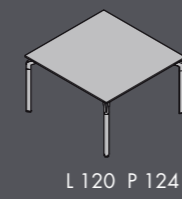
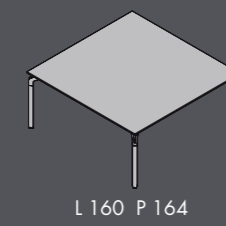
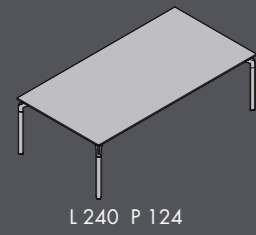
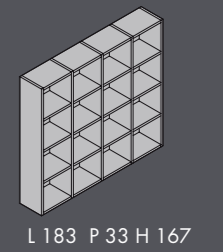
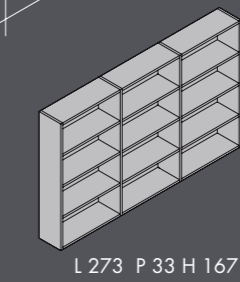
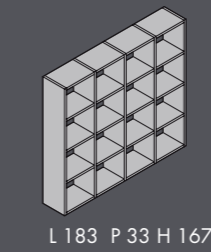
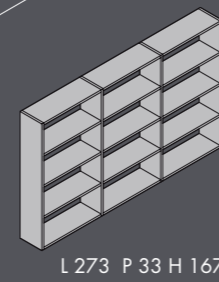
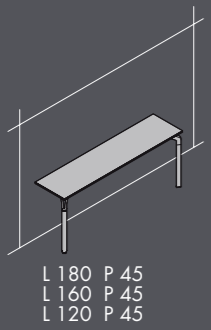
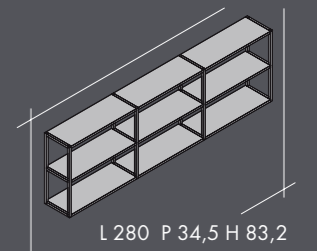
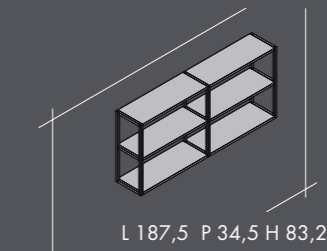
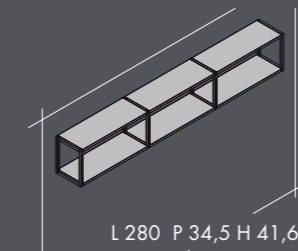
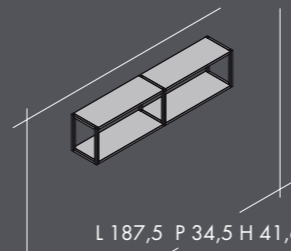
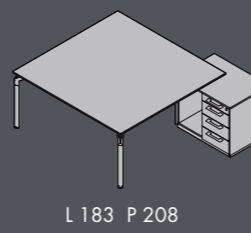
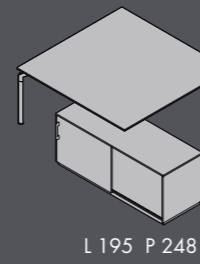
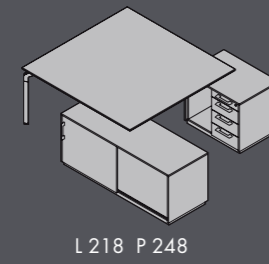
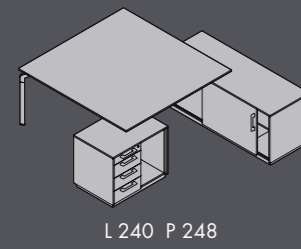
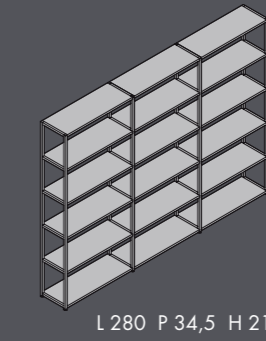
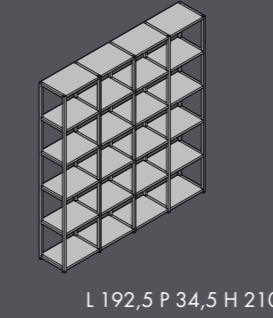
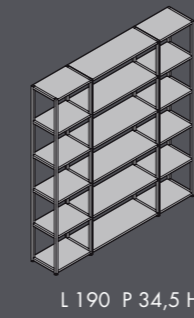
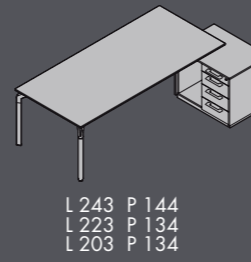
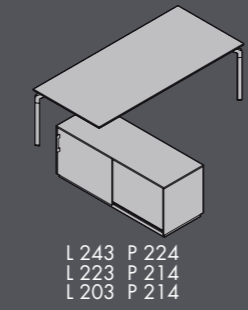
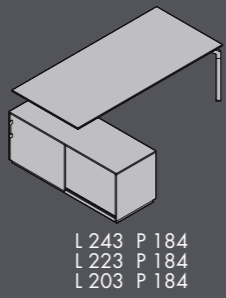
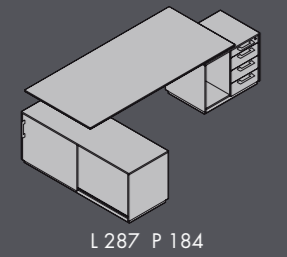
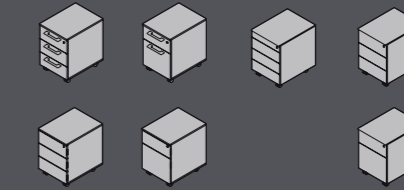
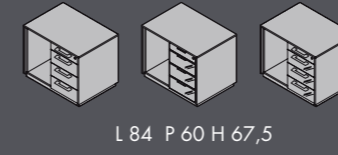
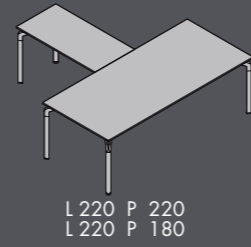
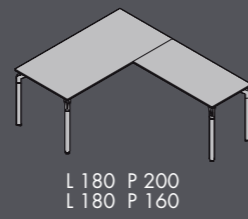
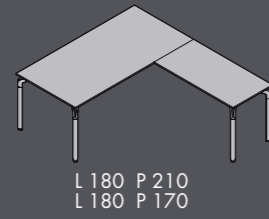
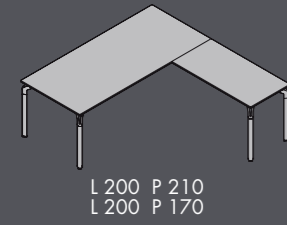
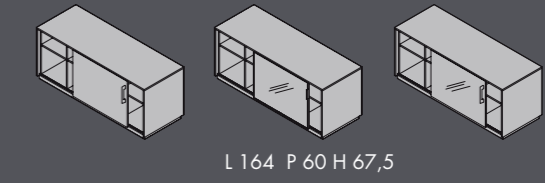
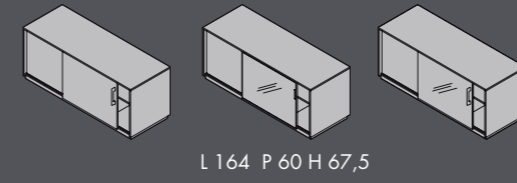
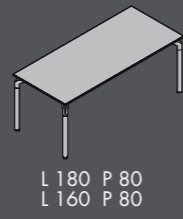
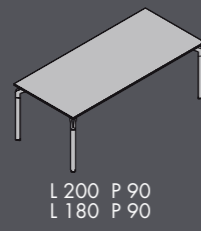
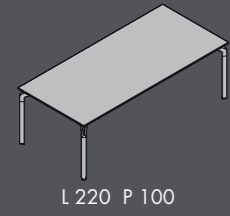

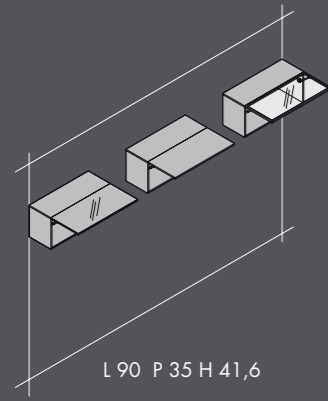

L 90 P 35 H 41,6

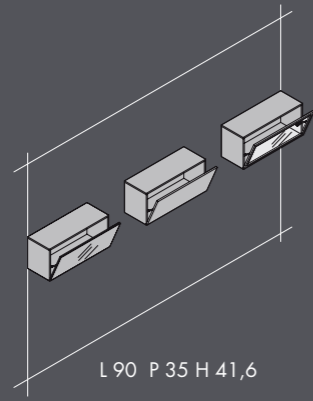

L 90 P 35 H 41,6

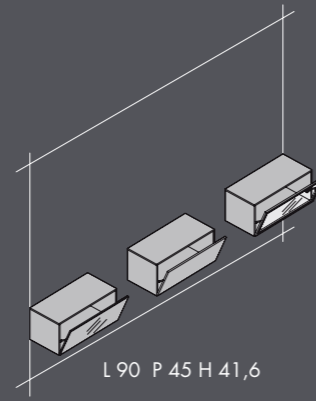

L 90 P 45 H 41,6

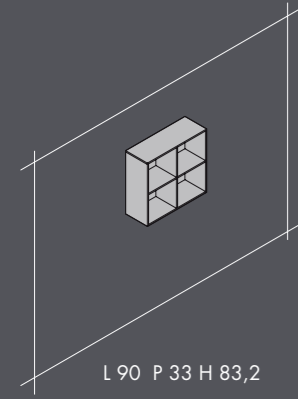

L 90 P 33 H 83,2

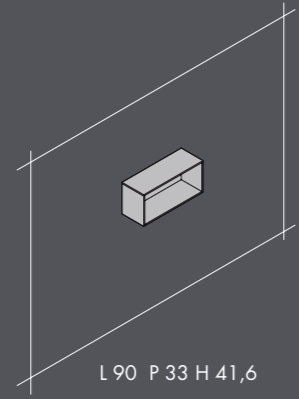

L 90 P 33 H 41,6

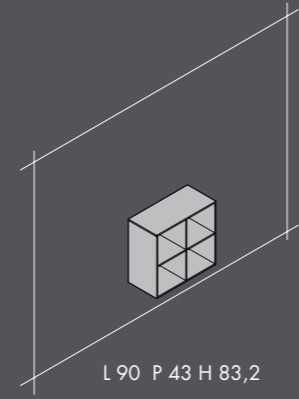

L 90 P 43 H 83,2

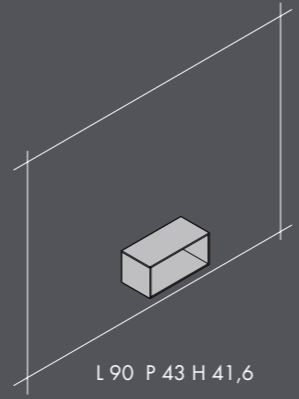

L 90 P 43 H 41,6

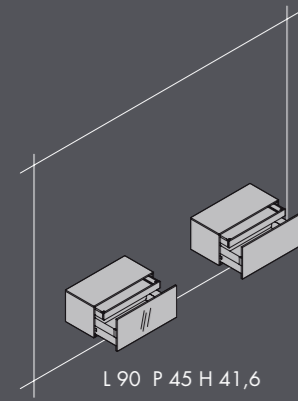

L 90 P 45 H 41,6

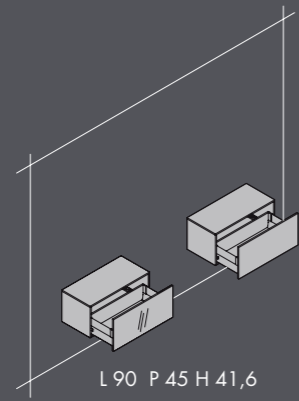

L 90 P 45 H 41,6

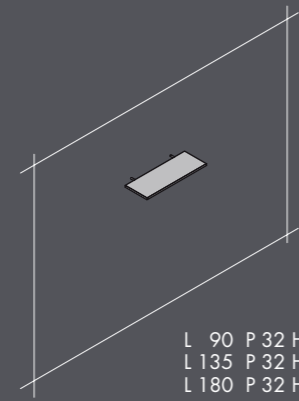

L 90 P 32 H 2,5
L 135 P 32 H 2,5
L 180 P 32 H 2,5

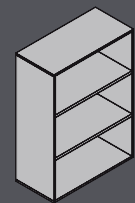

L 90 P 45 H 85
L 90 P 45 H 127
L 90 P 45 H 210

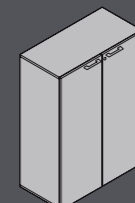

L 90 P 45 H 85
L 90 P 45 H 127
L 90 P 45 H 210

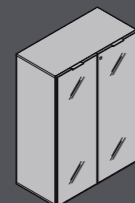

L 90 P 45 H 85
L 90 P 45 H 127
L 90 P 45 H 210

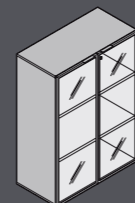

L 90 P 45 H 85
L 90 P 45 H 127
L 90 P 45 H 210

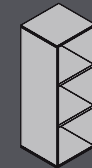

L 45 P 45 H 85
L 45 P 45 H 127
L 45 P 45 H 210

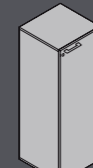

L 45 P 45 H 85
L 45 P 45 H 127
L 45 P 45 H 210

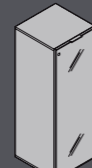

L 45 P 45 H 85
L 45 P 45 H 127
L 45 P 45 H 210

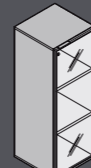

L 45 P 45 H 85
L 45 P 45 H 127
L 45 P 45 H 210

PAGG.	DESCRIZIONE MODELLO: DESCRIZIONE FINITURE
04-05	Scrivania direzionale L160 P164: piano N2WE - gambe A1CF - giunti A1CF Contentore portante L164 P60: struttura N3NJ - ante E1NY - telaio 20/45 A1AL - top e fianchi N2WE Mobili contenitori H85: ante N2WE - maniglie D914 - top e fianchi N2WE
06-07	Scrivania direzionale L200 P90: piano N3NS - gambe A1BD - giunti A1CF Contentore portante L164 P60: struttura N3BD - ante E1BD - telaio 20/45 A1AL - top e fianchi N3NS Libreria alluminio H210: struttura A2BD - ripiani E1BD
08-09	Scrivania direzionale L200 P90: piano E1BD - gambe A1BD - giunti A1CF Mobile di servizio L122 P55: ante N3LG - maniglie D904 - top e fianchi N3LG Mobili contenitori H85: ante N3LG - maniglie D914 - top e fianchi N3LG
10-11	Scrivania direzionale L220 P100: piano E1EC - gambe A1CF - giunti A1CF - travi A1CF Dattilo L120 P60: piano E1EC - gambe A1CF - giunti A1CF - travi A1CF Cassettiera: struttura e cassetti M3CF Tavolo riunioni L240 P124: piano N3RT - gambe A1CF - giunti A1CF Mobili contenitori H210: ante N3RT - maniglia D912 - top e fianchi N3RT
12-13	Scrivania direzionale L200 P90: piano V1GE - gambe A2NY - giunti A2NY - trave A2NY Contentore portante L164 P60: struttura L2NY - ante E1GY - telaio 20/45 A1AL - top e fianchi L2NY Libreria alluminio H210: struttura A2NY - ripiani E1NY Mobili contenitori H127: ante E1YG - telaio 20/45 A1AL - top e fianchi L2NY
14-15	Tavolo riunioni L160 P164: piano E1NY - gambe A1BD - giunti A1BD Libreria melaminico H167: struttura L2BD - ante push&pull E2GY - frameless
16-17	Scrivania direzionale L200 P90: piano N3BD - gambe A1BD - giunti A1BD Mobile di servizio L122 P55: ante N3BD - struttura N3BD Basi e pensili sospesi L90: struttura N3BD/N3NJ - ante push&pull N3BD/N3NJ
18-19	Scrivania direzionale L180 P90: piano N3RT - gambe A1NY - giunti A1NY Basi e pensili sospesi L90: struttura N3NJ - ante push&pull E1EC - telaio 20/20 A2NY
20-21	Scrivania con allungo L180 P210: piano I1NC - gambe A1BD - giunti A1BD Cassettiera: struttura e cassetti I1NC - maniglie D902 Tavolo tondo Ø120: piano E1EC - gambe A2BD - giunti A2BD - trave A2BD Mobili contenitori H210: ante I1NC - maniglie D912 - ante E1BD - telaio 20/45 A2BD - top e fianchi I1NC
22-23	Scrivania con allungo L200 P210: piano I1NS - gambe RAL1019 - giunti RAL1019 Cassettiera: struttura e cassetti I1NS - maniglie D905 Tavolo riunioni L320 P164: piano I1NS - gambe RAL1019 - giunti RAL1019 Basi e pensili sospesi L90: struttura L2RC - ante push&pull L2RC Libreria alluminio H210: struttura A1AL - ripiani L2RC
24-25	Scrivania con allungo L200 P210: piano N1NN - gambe A1CF - giunti A1CF Cassettiera: struttura e cassetti N1NN - maniglie D904 Mobili contenitori H85: ante N1NN - maniglie D914 - top e fianchi N1NN
26-27	Scrivania direzionale L200 P90: piano E1NY - gambe A1NY - giunti A1NY Mobile di servizio L122 P55: ante I1NS - maniglie D904 - top e fianchi E1NY Mobili contenitori H85: ante I1NS - maniglie D914 - top e fianchi I1NS Tavolo riunioni L480 P164: piano I1NS - gambe A1NY - giunti A1NY Mobili contenitori H127: ante E1NY - telaio 20/45 A1AL - top e fianchi I1NS
28-29	Scrivania direzionale L220 P100: piano L5TS - gambe A1BD - giunti A1BD Contentore portante L164 P60: struttura N3BD - ante E1BD - telaio 20/45 A1AL - top e fianchi L2TS Mobili contenitori H85: ante N3BD - maniglie D914 - top e fianchi N3RT Tavolo riunioni L160 P164: piano N3RT - gambe A1GY - giunti A1GY Basi e pensili sospesi L90: struttura N3BD - ante push&pull N3BD
30-31	Scrivania direzionale L180 P80: piano I1NS - gambe A1CF - giunti A1CF Contentore portante L164 P60: struttura N3BD - ante E1BD - telaio 20/45 A1AL - top e fianchi N3BD Mobili contenitori H127: ante E1BD - telaio 20/45 A1AL - top e fianchi N3BD
32-33	Scrivania direzionale L160 P164: piano L5GY - gambe A1GY - giunti A1GY Contentore portante L164 P60: struttura L2GY - ante L2GY - top e fianchi L2GY - maniglia D902 Contentore portante L84 P60: struttura L2GY - cassetti L2GY - top e fianchi L2GY - maniglia D902 Mobili contenitori H85: ante L2GY - maniglie D915 - top e fianchi L2GY
34-35	Scrivania direzionale L220 P100: piano N3RF Contentore portante L164 P60: struttura N3NJ - ante E1BD - telaio 20/45 A1AL - top e fianchi N3RF Contentore portante L84 P60: struttura N3NJ - cassetti N3RF - top e fianchi N3RF - maniglie D905 Tavolo riunioni L240 P124: piano N3RF - gambe A1BD - giunti A1BD Mobili contenitori H85: ante N3RF - maniglie D915 - top e fianchi N3RF
36-37	Libreria alluminio H210: struttura A1AL - ripiani E1NY Libreria alluminio H210: struttura A2BD - ripiani L2NY
38-39	Scrivania direzionale con allungo frontale L220 P220: piano N2WE - gambe A1CF - giunti A1CF Gonna frontale H41: struttura N2WE Cassettiera: struttura e cassetti M3CF Mobili contenitori H210: ante N2WE - maniglie D915 - ante E1NY - telaio 20/45 A1AL - top e fianchi N2WE
42-43	Tavolo riunioni L480 P164: piano N3LG - gambe A1BD - giunti A1BD Mobili contenitori H210: struttura N3BD - ante N3LG - maniglia D914
44-45	Tavolo riunioni L160 P164: piano RAL8022 - gambe A1BD - giunti A1CF Tavolo tondo Ø120: piano E2BD - gambe A1BD - giunti A1CF Libreria melaminico H167: struttura RAL8022 - ante push&pull E2BD
46-47	Tavolo riunioni L480 P164: piano N3CB - gambe A1BD - giunti A1BD Mobili contenitori H210: struttura N3BD - ante N3CB - maniglie D915
48-49	Tavolo riunioni L240 P124: piano E1EC - gambe A2NY - giunti A2NY - trave A2NY Mobili contenitori H85: ante N3NS - maniglie D915 - top e fianchi N3NS
50-51	Tavolo riunioni L240 P124: piano E1EC - gambe A2NY - giunti A2NY - trave A2NY Mobili contenitori H210: struttura N3NJ - ante N3RT - maniglie D904 Libreria alluminio H210: struttura A2NY - ripiani L2NY
52-53	Tavolo riunioni L240 P124: piano N3NS - gambe A1CF - giunti A1CF Mobili contenitori H85: ante N3NS - maniglie D915 - top e fianchi N3NS Pensili alluminio: struttura A1AL - ripiani N3BD Consolle L180 P45: piano I1NS - gambe A1CF - giunti A1CF Cassettiera: struttura e cassetti M3CF Pensili alluminio: struttura A2BD - ripiani N3BD
54-55	Scrivania direzionale L180 P80: piano N1NN - gambe A1CF - giunti A1CF Contentore portante L164 P60: struttura N3BD - ante N1NN - maniglia D905 - top e fianchi N1NN Gonna frontale H41: struttura N1NN