

KO

KONO

OY



KONO, IL PROGETTO CHE DA ELEGANZA ALL'UFFICIO DIREZIONALE CONTEMPORANEO. CREATO NEL SEGNO DI UN AFFASCINANTE MINIMALISMO CHE SI SPOSA CON QUALSIASI CORNICE ARCHITETTONICA E STILISTICA. UN SISTEMA STRUTTURALE IN ALLUMINIO CHE TROVA LA SUA IDENTITÀ NEL GIUNTO CHE RACCORDA STRUTTURA PERIMETRALE E GAMBE. UN'IDEA DI DESIGN CHE SI MATERIALIZZA IN SOLUZIONI CROMATICHE E MATERICHE OGNI VOLTA DIVERSE, VESTENDOSI DI SENSAZIONI ED EMOZIONI CLASSICHE, NATURALI O GLAMOUR. KONO È LA COLLEZIONE CHE CONCILIA ESTETICA, PRESTIGIO ED ESSENZIALITÀ.



Kono, the project that gives elegance to the contemporary executive office. Characterized by a fascinating minimalism that merges with any architectural and stylistic environment. A structural system in aluminium that expresses its identity with the joint that connects perimeter structure and legs. A design idea that materializes in color and material solutions different every time, dressing with classical, natural or glamour feelings and emotions. Kono is the collection that merges beauty, luxury and essential.

Kono, le projet que donne elegance au bureau de direction contemporain, crée avec un minimalisme fascinant, que s'épouse avec ne importe quel style et architecture. Un système structural en aluminium, que trouve son identité dans le joint que relie la structure et les pieds. Une idée de design que se materialise dans les couleurs et les matériaux chaque fois différents, donnant sensations classiques, naturelles ou glamour. Kono est la collection qu' unit l'esthétique, le prestige et l'essentiel.





DETTAGLI CHE FANNO LA DIFFERENZA.

*Details that make the difference.
Détails que font la différence.*

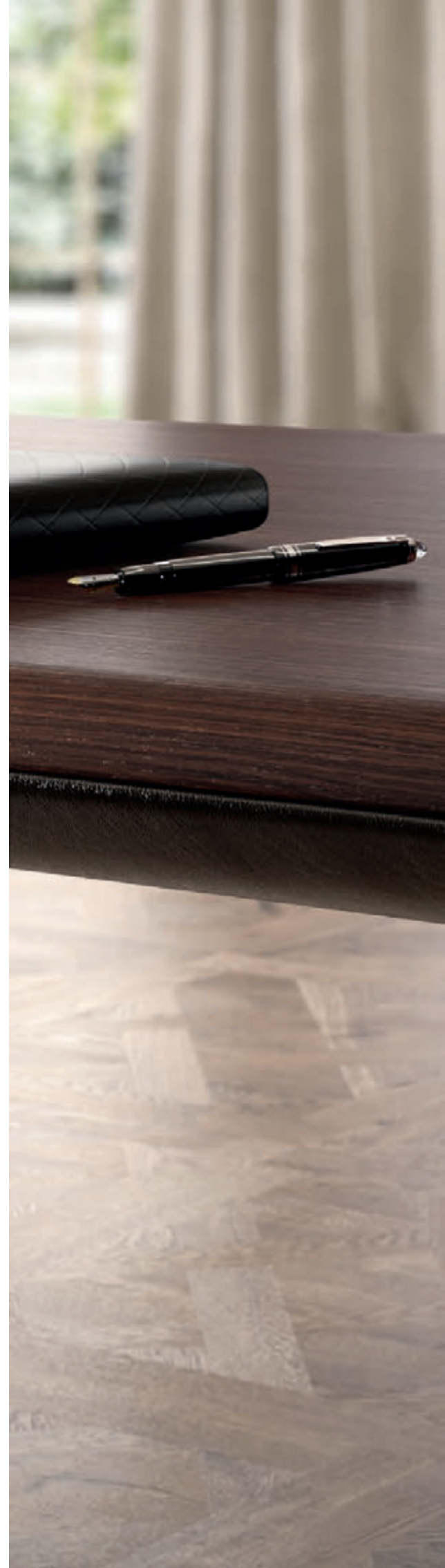













UN SISTEMA MODULARE CHE PERMETTE DI ALLUNGARE ALL'INFINITO IL TAVOLO RIUNIONI, E PREVEDE IL CONTENIMENTO E IL PASSAGGIO DELL'ELETRIFICAZIONE.

A modular system that enables infinite extensions of meeting tables and provides integrated cable ways as well as full wire management.

Un système modulaire que permet d'allonger à l'infini une table de réunion, et prévoit le logement et le passage des câbles.













SUPERFICI ACCOSTATE CON CURA SARTORIALE,
CREANO UNA SOLIDA ARMONIA TRA FORMA E MATERIA.

*Carefully combined surfaces create a solid harmony
from shape and material.*

*Surfaces jointes soigneusement créent un équilibre
solide entre la forme et le matériel.*











VOLUMI SINGOLI, CHE DIALOGANO TRA LORO
IN MODO FUNZIONALE ED ELEGANTE.

*Individual volumes that dialogue with each other in
a functional and elegant way.*

*Volumes uniques, que dialoguent entre eux
de manière fonctionnelle et élégant.*







TOTAL WHITE: UN UFFICIO ETereo ED ELEGANTE
RICCO DI PREZIOSI DETTAGLI.

*An ethereal and elegant office
is filled with precious details.*

*Un bureau etereal et elegant,
riches des details precieux.*











PIANI IN PELLE MORBIDEZZA, ESCLUSIVITÀ DEI DETTAGLI, MAESTRIA NELLE LAVORAZIONI.
PER UNA SCRIVANIA UNICA, DA SFIORARE CON LE DITA E GLI OCCHI.

*Leather covered worktops: softness, exclusive details, mastery in craftsmanship.
For a unique desk, to graze with sense of sight and touch.*

*Plateaux en cuir: douceur, exclusivité dans les détails, maîtrise dans la réalisation,
pour un bureau exclusif, à toucher avec la vue et les doigts.*







MATERIALI PREGIATI CHE VESTONO DI
NUOVA ELEGANZA OGNI AMBIENTE.

*Precious materials that dress any environment
with a new elegance.*

*Matériaux précieux qui donnent à chaque
ambiance une nouvelle élégance.*







PREZIOSO, DECISO, UNICO.
IN EQUILIBRIO FRA CLASSICITÀ ED INNOVAZIONE.

*Precious, firm, unique.
Striking a balance between classical forms and innovation.*

*Précieux, défini, unique.
Un équilibre parfait entre classicisme et innovation.*







ELEGANZA SUPERIORE CHE RISPECCHIA IL CARATTERE DEL LEADER.
L'ABITO SCURO DELLA STRUTTURA CONFERISCE ELEGANZA DOMESTICA
E SIGNORILITÀ PROFESSIONALE.

*Superior elegance that reflects the character of the leader.
The dark clothing of its structure provides a touch of domestic
elegance together with professional distinction.*

*Élégance supérieure que reflète le caractère du chef.
La finition sombre de la structure donne confort
et élégance professionnelle.*



CRISTALLO BIANCO EXTRACHIARO E ALLUMINIO COLOR TITANIO:
L'ESSENZA DELLA LEGGEREZZA, PER FORME PURE E SENZA TEMPO.

*Extralight white glass and aluminum titanium color:
the essence of lightness, for pure and timeless shapes.*

*Verre blanc extraclair et aluminium couleur titane:
des formes pures et intemporelles, symboles d'élégance et de légèreté.*

















KONO È ALLUMINIO.
IL LEGNO, I LACCATI, IL CRISTALLO E LA PELLE CREANO
UN'AFFASCINANTE CONTRASTO.

*Aluminum is the core material of Kono.
Veneers, lacquered, glass surfaces
and leather provide a luxury contrast.*

*L'aluminium est le matériau du Kono.
Bois plaqué, laqué, verre et cuir offrent
le contraste du luxe.*





I DETTAGLI RIVELANO
LA CLASSE DELLA COLLEZIONE.

*The true class of this collection
is revealed in the details.*

*La vraie classe de la collection
se révèle dans les détails.*





LEGNO
Wood veneer
Bois plaqué

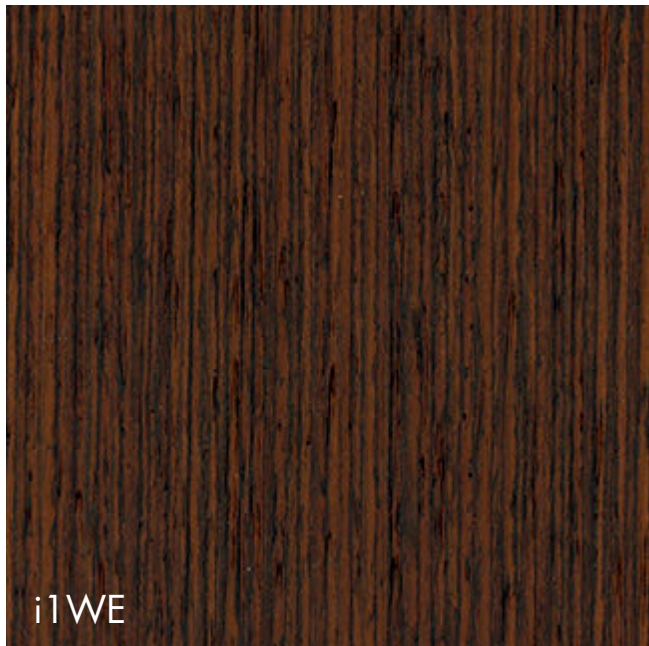

Wengè
Wengé . Wengé

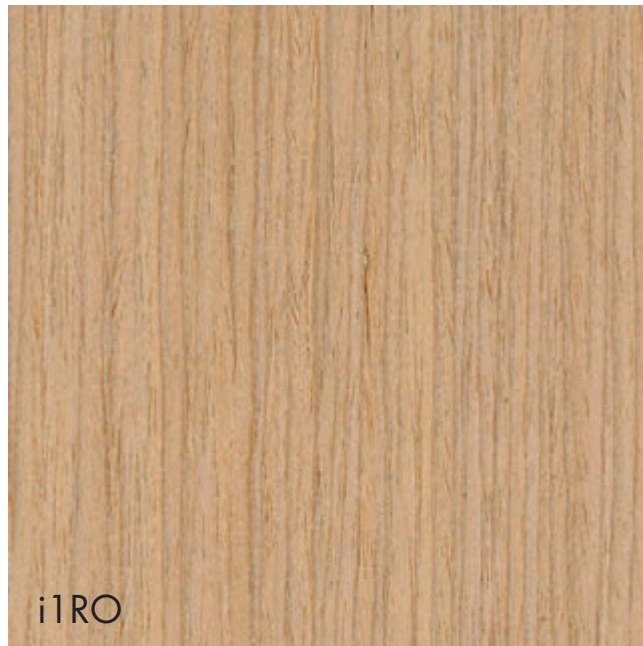

Rovere
Durmast . Chêne

LACCATO OPACO
Matt laquered
Laqué mat

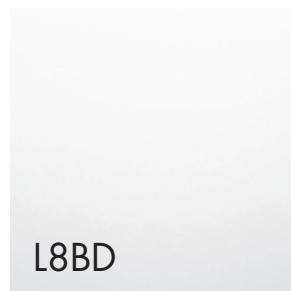

Bianco Dance
White Dance . Blanc Dance



Titanio
Titanium . Titane



Nero
Black . Noir

ALLUMINIO
Aluminium
Aluminium

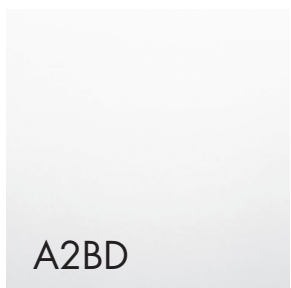

Bianco Dance
White Dance . Blanc Dance

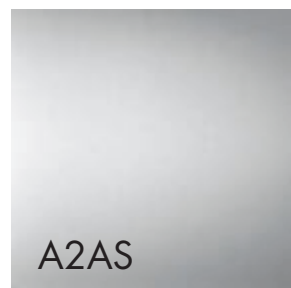

Alluminio Silver
Silver Alu . Alu Argenté

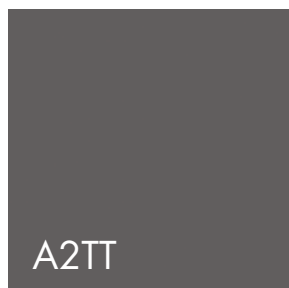

Titanio
Titanium . Titane

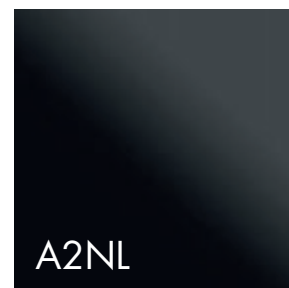

Nero Lucido
Glossy Black . Noir Brillant

MELAMINICO
Melamine
Mélamine

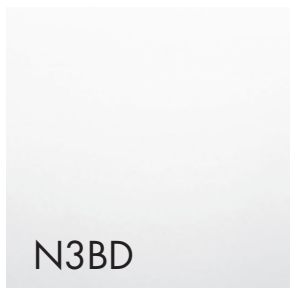

Bianco Dance
White Dance . Blanc Dance



Grigio Nuvola
Gray Cloud . Nuage Gris



Titanio Treddi
3D Titanium . Titane 3D

SOLO PER STRUTTURE CONTENITORI
Only for storage structure
Uniquement pour structures des armoires

FINITURE
Finishes - Finitions



PELLE
Leather
Cuir



P1BG

Beige
Beige . Beige



P1AT

Asfalto
Asphalt . Asphalte



P1MS

Marsala
Marsala . Marsala

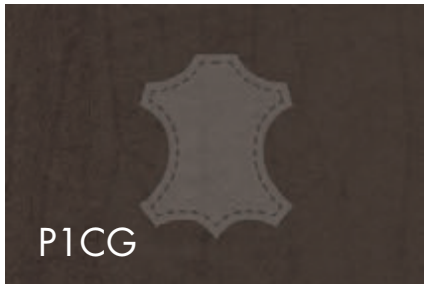

P1CG

Castagna
Chesnut . Châtaigne



P1BN

Blu Notte
Night Blue . Bleu Nuit

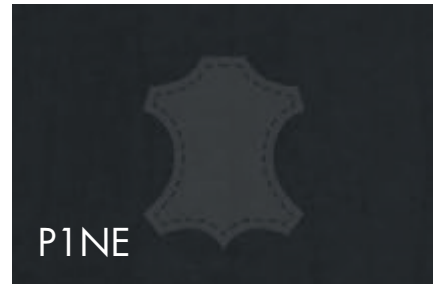

P1NE

Nero
Black . Noir

VETRO LACCATO
Laquered glass
Verre laqué

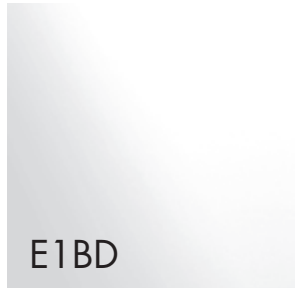

E1BD

Bianco Dance
White Dance . Blanc Dance

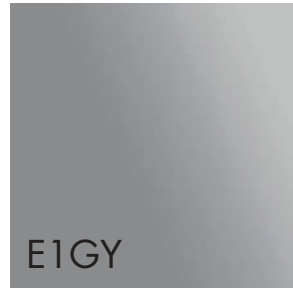

E1GY

Grigio Yoga
Grey Yoga . Gris Yoga

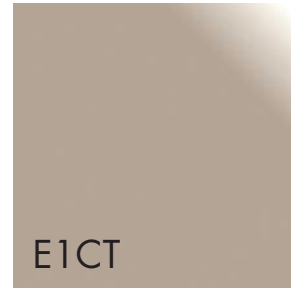

E1CT

Cappuccino
Cappuccino . Cappuccino

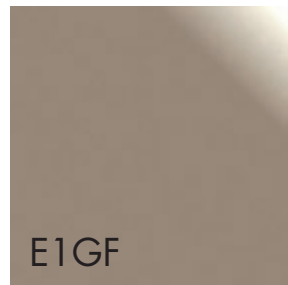

E1GF

Grigio Fango
Mud Grey . Gris Boue

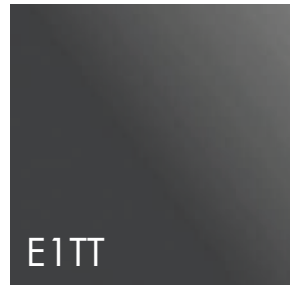

E1TT

Titanio
Titanium . Titane



E1MS

Marsala
Marsala . Marsala



V1BV

Blu Vivo
Sparkling Blue . Blue Vif

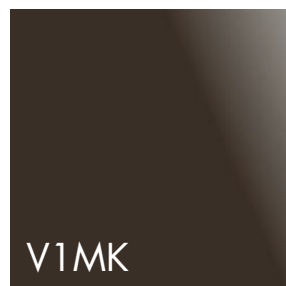

V1MK

Moka
Moka . Moka

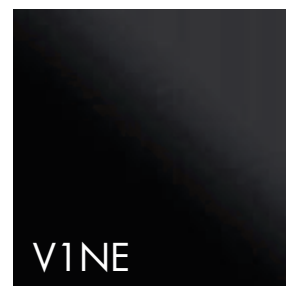

V1NE

Nero
Black . Noir



PIANI DI LAVORO Worktops - Plateaux

PIANI SMUSSATI SP 26 mm
Shaped edge worktops th 26 mm
Plateaux avec bord en forme ep 26 mm

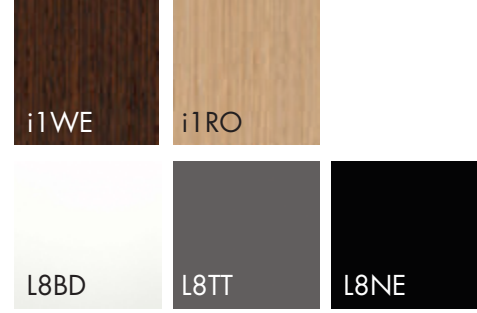

PIANI SP 19 mm
Worktops th 19 mm
Plateaux ep 19 mm

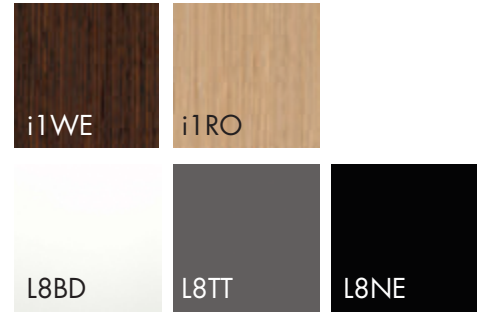

PIANI IN PELLE SP 20 mm
Leather worktops th 20 mm
Plateaux en cuir ep 20 mm

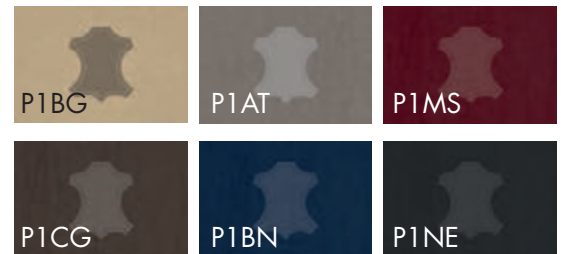

PIANI DI LAVORO E FIANCHI LATERALI
 Worktops and side panels - Plateaux et panneaux latéral



PIANI IN VETRO SP 12 mm
 Glass worktops th 12 mm
 Plateaux en verre ep 12 mm

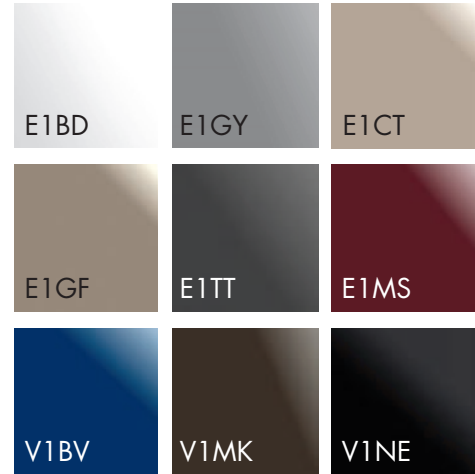

PIANI IN VETRO SP 10 mm
 Glass worktops th 10 mm
 Plateaux en verre ep 10 mm



FIANCHI LATERALI
 Side panels
 Panneaux latéral





ALLUMINIO VERNICIATO
Painted aluminum
Aluminium laqué

STRUTTURA
Structure - Structure

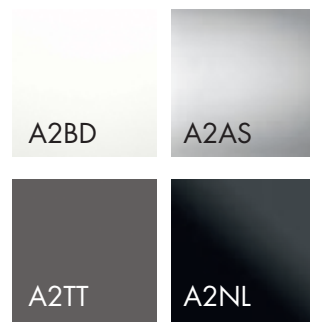

ALLUMINIO RIVESTITO PELLE
Aluminum with leather upholstery
Aluminium avec revêtement en cuir

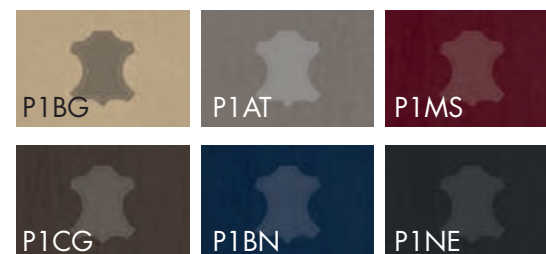

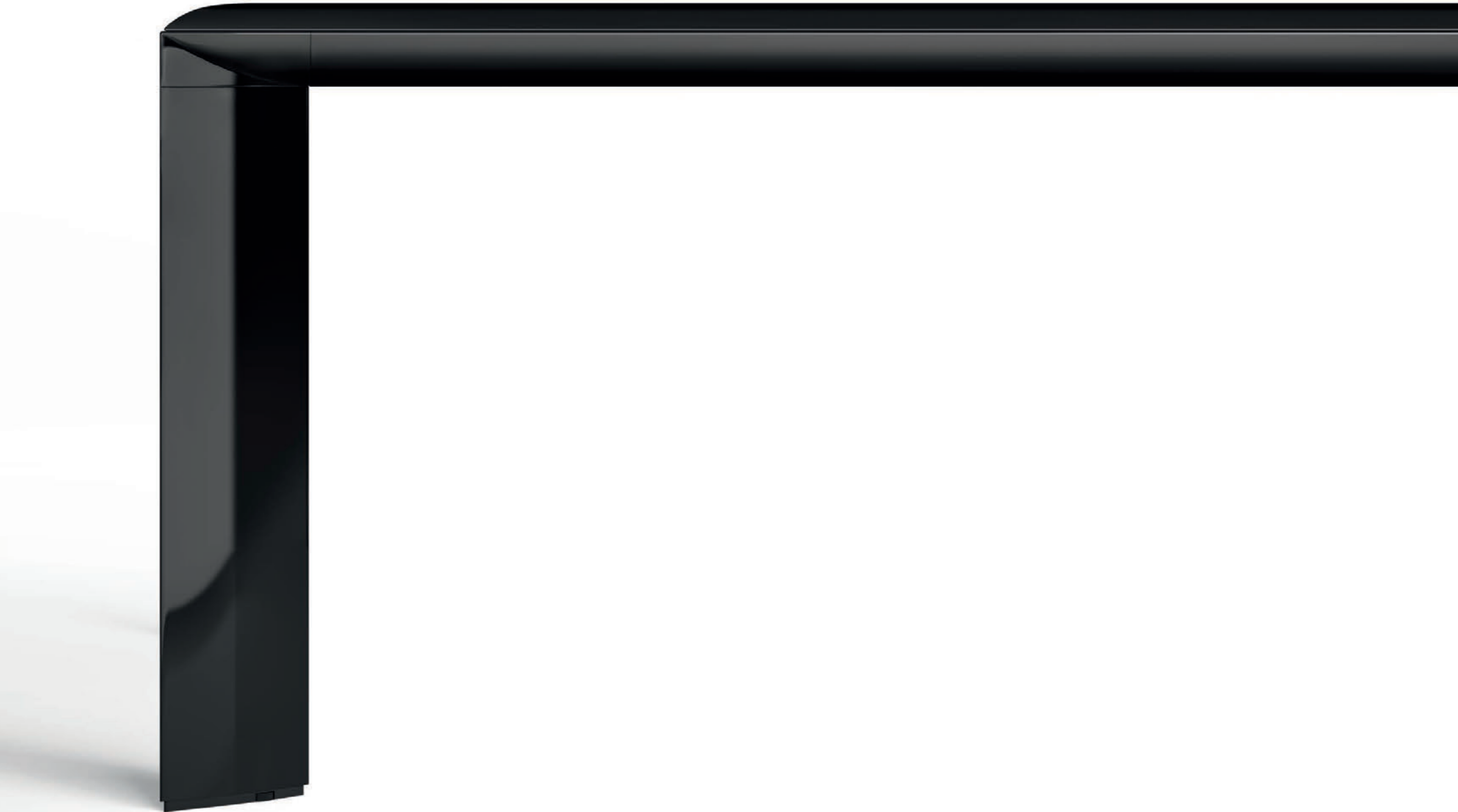

SCRIVANIE E CONSOLE _ Desks and console _ Bureaux et console

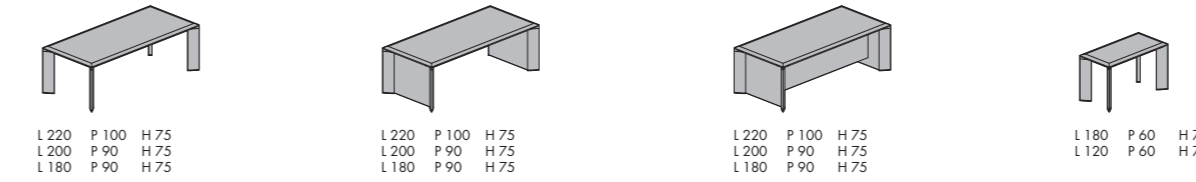

SCRIVANIE IN APPOGGIO _ Hanging desks _ Bureaux pour pont de service

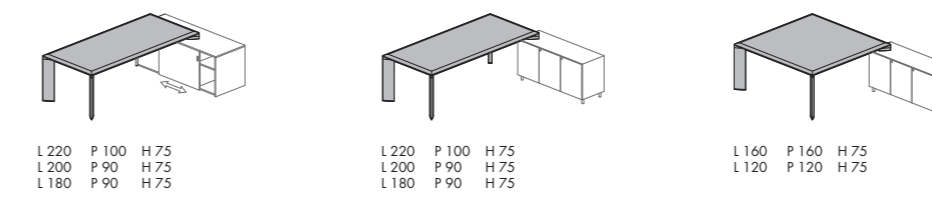

MOBILI STRUTTURALI PORTANTI O INDIPENDENTI _ Independent or desk supporting structural containers _ Rangement indépendante ou de soutien aux bureaux pour compositions

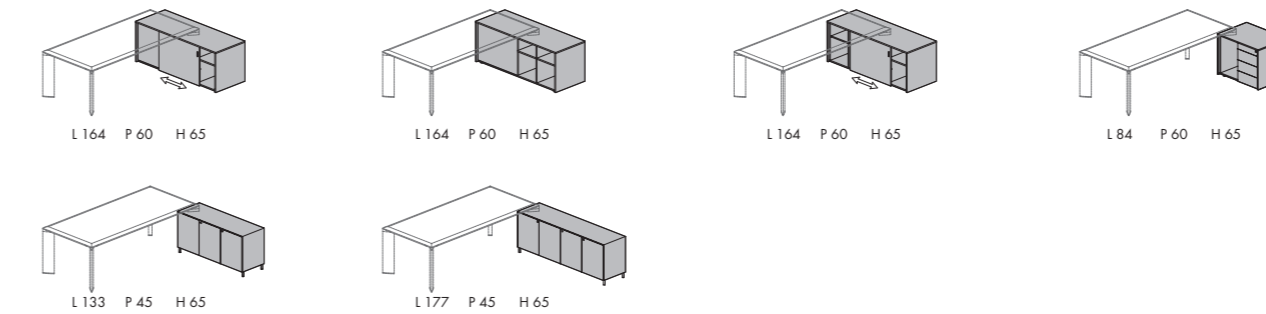

CASSETTIERE E MOBILI DI SERVIZIO SU RUOTE _ Pedestals and service units with castors _ Caissons et meubles de rangement avec roulettes



MOBILI INDIPENDENTI, LIBRERIE E BOISERIE _ Cupboards, bookcases and wall shelving _ Rangements, bibliothèques et boiserie

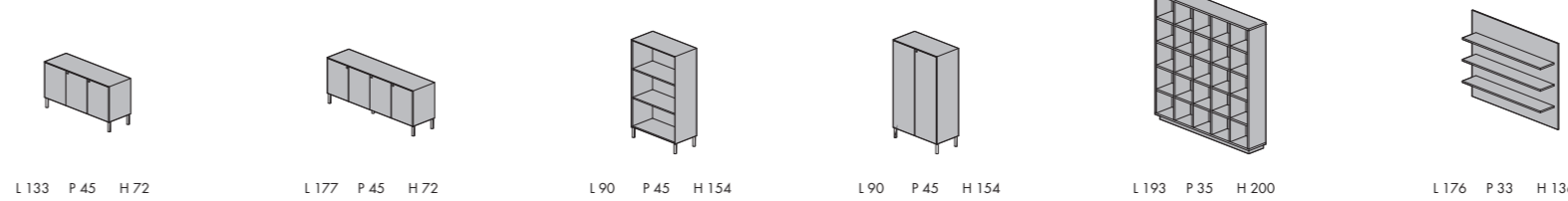

CONTENITORI SOSPESI A MURO _ Wall fixed containers _ Element de rangements suspendus

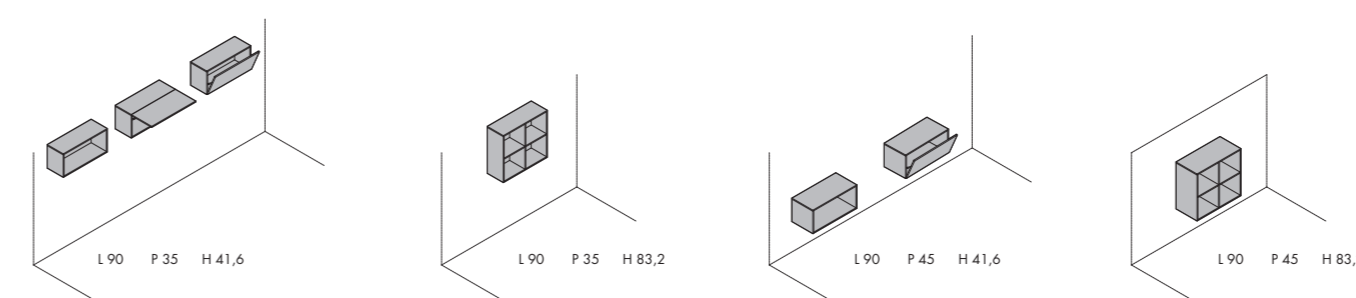

TAVOLI RIUNIONE _ Meeting tables _ Tables de reunion

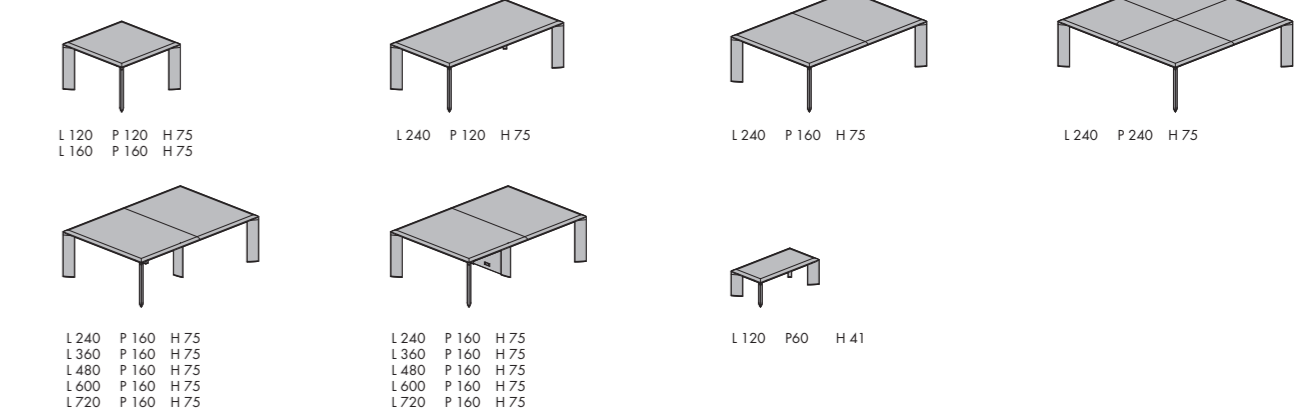

LIBRERIE IN ALLUMINIO _ Aluminum bookcases _ Bibliothèques en aluminium

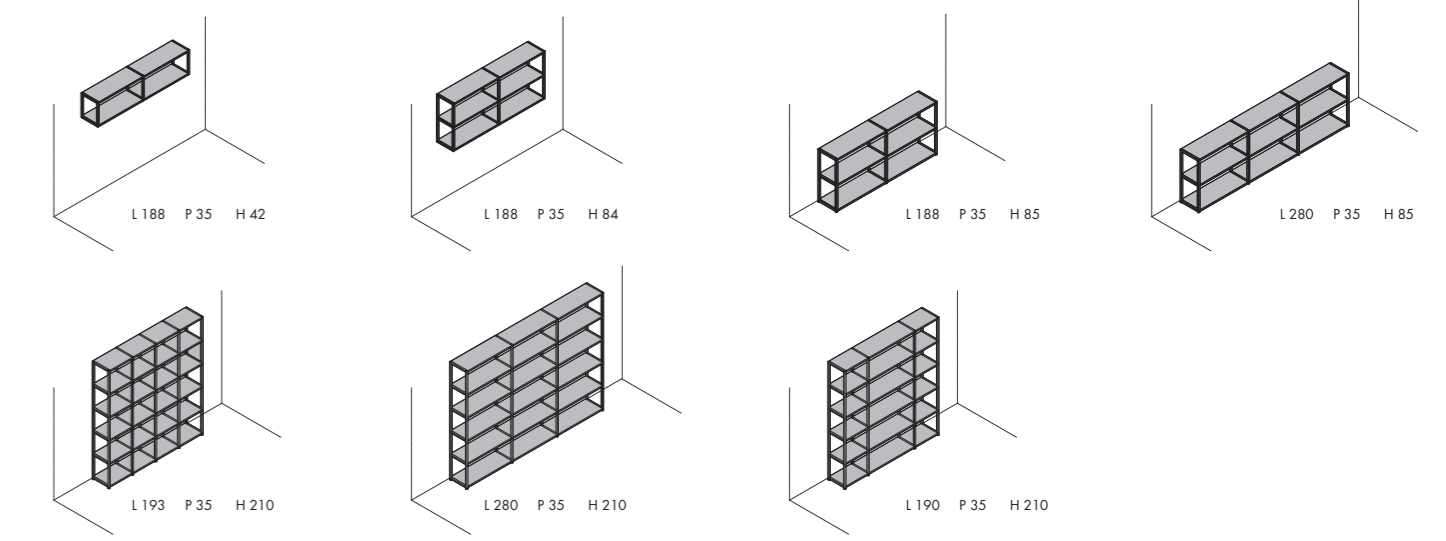

CONTENITORI _ Storage units _ Armoires

