

STIMEX

●
Design Luisa Battaglia

Scocca in policarbonato.
Cinque diverse tipologie di struttura ne fanno un prodotto
ideale per spazi pubblici, locali, alberghi.
Per uso interno.

*Polycarbonate main body.
Five different types of frame make it an ideal product for public
areas, cafés and restaurants, hotels.
For indoor use.*



2274 183



2273 100



2605 140

●
Zebra antishock



2273 VE 310
4 gambe - acciaio zincato e verniciato bianco
per uso interno/esterno
*4 legs - white zinc and coated steel
for indoor/outdoor use*



2274 381
nuovo colore antracite
new colour anthracite grey



2273 381
nuovo colore antracite
new colour anthracite grey



2601 310
girevole su trespolo
revolving on trestle base



2602 310
con ruote
with castors

●
Design Luisa Battaglia

Scocca in tecnopolimero.
Una seduta dall'eleganza minimal, con linee morbide ed ergonomiche,
per accogliere e sostenere al meglio la schiena di chi la utilizza.
Disponibile con quattro tipologie di struttura.
Per uso interno.

*Technopolymer main body.
It is a chair with minimalist elegance and soft and ergonomic lines to give
the best support to the back of its user.
Available with four types of frame.
For indoor use.*



Novità

2615 30

●
Zebra tecnopolimero



2615 15

2615 11



2616 62
con braccioli
with armrests

2617 81
girevole su trespolo
revolving on trestle base



2618 11
slitta
sledge

●
Design Luisa Battaglia

Scocca in policarbonato trasparente, trasparente colorato o bianco pieno.
La seduta è fotoincisa sulla parte a contatto con un originale decoro sinuoso.
Disponibile con tre tipologie di struttura.
Per uso interno.

*Transparent or translucent coloured polycarbonate main body, also in glossy white.
The seat is screen printed on the contact part with an original sinuous design.
Available with three types of frame.
For indoor use.*



2271 100



Zebra



2600 130

●
Design Luisa Battaglia

Sedia bicolore con scocca in polimero.
Parte interna bianco lucido, esterno con superficie lucida sfaccettata.
Struttura a 4 gambe in tubo d'acciaio zincato e verniciato per uso interno/esterno.
Nelle tipologie con struttura cromata a 4 gambe, con braccioli e a trespolo
è indicata per uso interno.

*Two colour polymer main body chair.
Inner side in polished white, outer side with faceted polished surface.
Zinc and coated steel tube 4 legs frame for indoor/outdoor use.
The chrome steel types with 4 legs, armrests and the version on trestle base
are recommended for indoor use.*



2272 214

●
Zebra bicolore

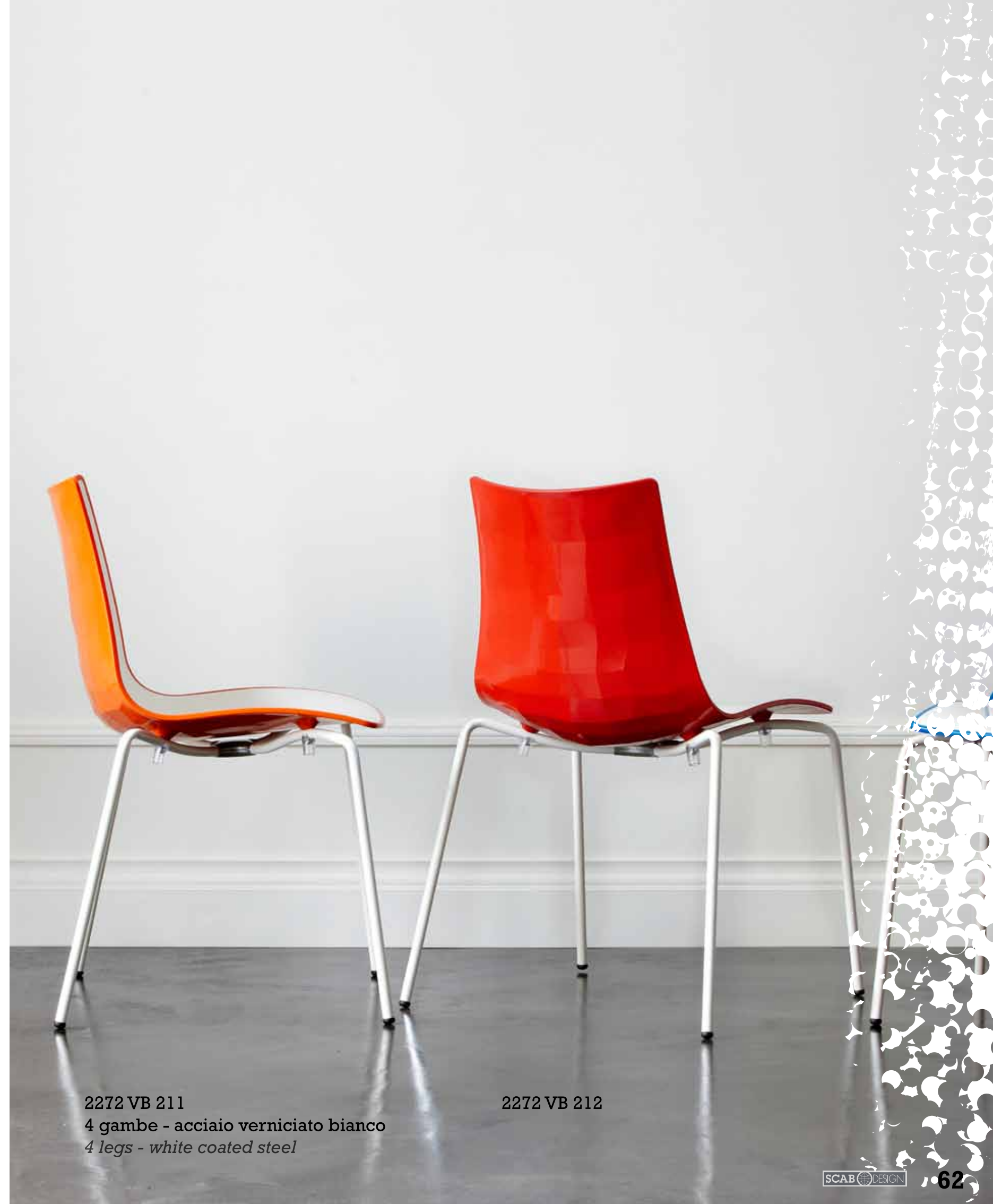

2272 VB 211
4 gambe - acciaio verniciato bianco
4 legs - white coated steel

2272 VB 212



2611 214
girevole su trespolo
revolving on trestle base



2272 213
4 gambe - acciaio cromato
4 legs - chromed steel



2610 214
con braccioli - acciaio cromato
with armrests - chromed steel

Natural Zebra

Natural Zebra pop

Pop

Design Centro Stile SCAB

Scocca imbottita con anima in policarbonato antishock.
Telaio in faggio naturale o tinto wengè.

*Upholstered main body with antishock polycarbonate core.
Natural or wenge stained beech frame.*

FINITURE / FINISHES

FINITURA TELAIO FRAME FINISHING



FN
Faggio naturale
Natural beech wood

TESSUTI / FABRICS

similpelle / simil-leather

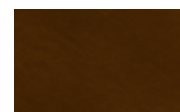

EP 73



EP 74



EP 75

lana / wool



WO 91



WO 93



WO 94

tessuto / fabric



T3 25



T4 52



T4 55

tessuto / fabric



T3 25



T4 53



FW
Faggio tinto wengè
Wenge stained beech wood

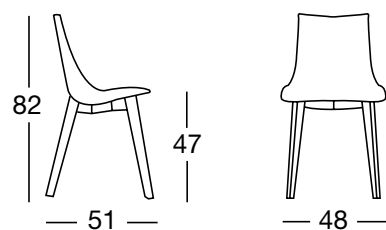

2806

natural
zebra pop



2806 FW T4 53

2806 FN WO 91

2806 FN EP 74

Natural Zebra

con cuscino

antishock

*Natural Zebra antishock
with cushion*

Design Centro Stile SCAB

Scocca in policarbonato e cuscino tessile fisso applicato al sedile.
Telaio in faggio naturale.

*Polycarbonate main body and fixed fabric seat cushion.
Natural beech wood frame.*

FINITURE / FINISHES

MATERIALE MATERIAL

scocca policarbonato
polycarbonate main body



100



310

FINITURA TELAIO FRAME FINISHING



FN
Faggio naturale
Natural beech wood

TESSUTI / FABRICS

similpelle / simil-leather



71



72

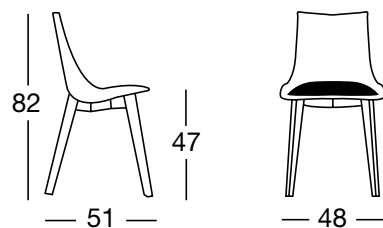

2806

natural
zebra
antishock

Made of Makrolon™ by
Bayer MaterialScience



2806 FN 310 71

2806 FN 310 72

Sgabelli Zebra

con cuscino

antishock

*Zebra antishock barstools
with cushion*



FINITURE / FINISHES

MATERIALE / MATERIAL

scocca policarbonato
polycarbonate main body



100



310



380

A richiesta sono disponibili tutte le combinazioni tra i tessuti proposti e gli ulteriori colori delle scocche disponibili per ogni modello.

On request, all combinations with the fabrics offered and further colours of the main bodies available are possible.

Made of Makrolon® by
Bayer MaterialScience

TESSUTI / FABRICS

tramato / woven



33

vellutino / velvet



41

similpelle / simil-leather



71



72

tecnotessuto / technofabric



61

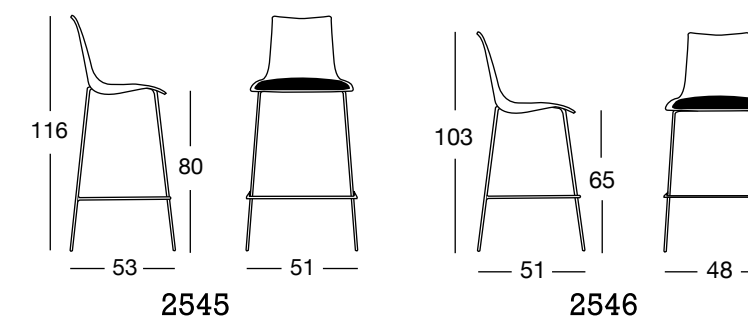

4 gambe
4 legs

Design Centro Stile SCAB

Sgabello con scocca in policarbonato e cuscino tessile fisso applicato al sedile.
Disponibile in 2 altezze.

*High stools with polycarbonate main body and fixed fabric seat cushion.
Available in two heights.*



h.65
2546 310 41



h.80
2545 100 33



h.80
2545 380 41



Sgabello Zebra antishock h.80 - h.65
con cuscino - with cushion

tessuto, similpelle, tecnotessuto / fabric, simil-leather, technofabric

Zebra

con cuscino

Zebra antishock with cushion

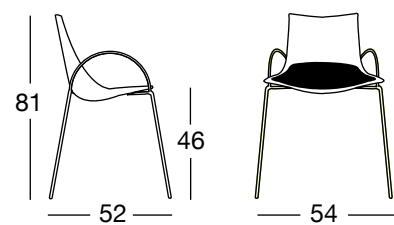

2605

braccioli
armrests

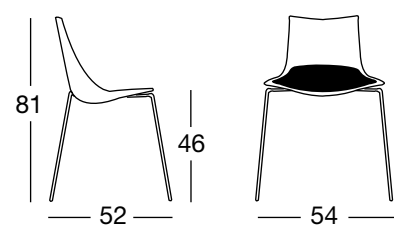

2273

4 gambe
4 legs

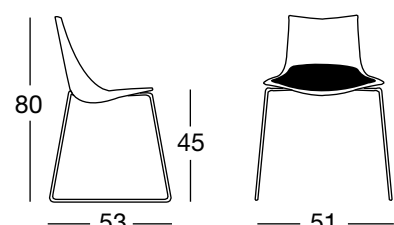

2274

a slitta
sledge

antishock

FINITURE / FINISHES

MATERIALE / MATERIAL

scocca policarbonato
polycarbonate main body

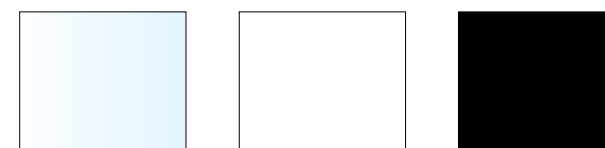

100

310

380

Per modelli 2605 - 2273 - 2274

Models 2605 - 2273 - 2274

A richiesta sono disponibili tutte le combinazioni tra i tessuti proposti e gli ulteriori colori delle scocche disponibili per ogni modello.

On request, all combinations with the fabrics offered and further colours of the main bodies available are possible.

Made of Makrolon® by



TESSUTI / FABRICS

tramato / woven



33

vellutino / velvet



41

similpelle / simil-leather



71



72

tecnotessuto / technofabric



61

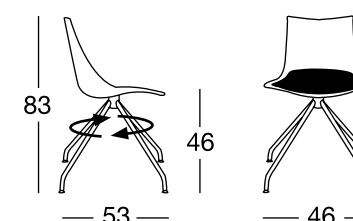

2606

trespolo
trestle base

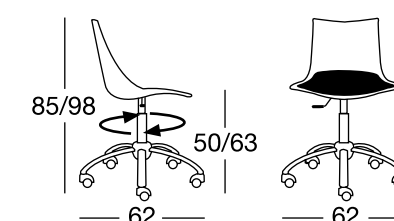

2607

con ruote
with castors

MATERIALE / MATERIAL

scocca policarbonato
polycarbonate main body



100

Per modelli 2606 - 2607
Models 2606 - 2607

●
Design Centro Stile SCAB

Scocca in policarbonato e cuscino tessile fisso applicato al sedile.
Disponibile con diverse tipologie di struttura.

*Polycarbonate main body and fixed fabric seat cushion.
Suitable with different types of frame.*



2605 310 33



2606 100 33



2607 100 72

●
Zebra antishock con cuscino - with cushion

Zeus antishock con cuscino

Zeus antishock with cushion

Design Luisa Battaglia

Scocca in policarbonato e cuscino tessile fisso applicato al sedile.
Struttura in nylon a 5 razze con ruote, girevole e regolabile in altezza a gas.
Ideale per uso home office.

*Polycarbonate main body and fixed fabric seat cushion.
Revolving frame, adjustable height with gas piston.
Base on castors with 5 nylon spokes.
Ideal for home-office use.*

FINITURE / FINISHES

MATERIALE / MATERIAL

scocca policarbonato
polycarbonate main body



100

Made of Makrolon® by



TESSUTI / FABRICS

tramato / woven



33

vellutino / velvet



41

similpelle / simil-leather



71



72

tecnotessuto / technofabric

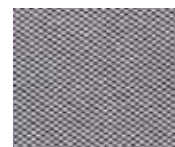

61

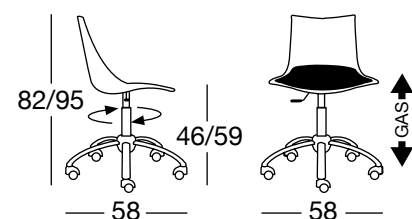

2665

con ruote
with castors



2665 100 71

tessuto, similpelle, tecnotessuto / fabric, simil-leather, technofabric

Sgabello Natural

Natural Zebra Pop barstool

FINITURE / FINISHES

FINITURA TELAIO FRAME FINISHING



FN
Faggio naturale
Natural beech wood

TESSUTI / FABRICS

tessuto / fabric



T3 25

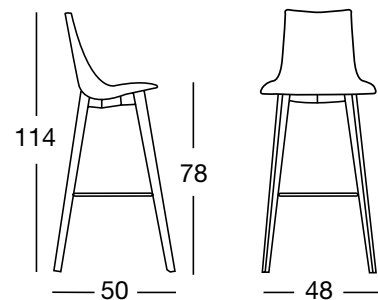

2812

sgabello
natural
zebra pop

Zebra Pop

Design Luisa Battaglia

Scocca imbottita
con anima in policarbonato antishock.
Telaio in faggio naturale.
Nuovo rivestimento in tessuto grigio classico.

*Upholstered main body
with antishock polycarbonate core.
Natural beech frame.
New classic grey fabric upholstery.*



2812 FN T3 25

Design Luisa Battaglia

Scocca in policarbonato antishock.
Telaio in essenza di faggio naturale.
Si distingue per eleganza sia in ambienti privati sia in luoghi pubblici
e contesti di lavoro.

*The main body is made from shockproof polycarbonate.
The frame is in natural beech essence. It stands out for its elegance
both in private and public places and the workplace.*



2810 FN 310

Sgabello Natural Zebra antishock

Design Luisa Battaglia

Scocca imbottita con anima in policarbonato antishock.
Telaio in faggio naturale.
Nuovo rivestimento in tessuto grigio classico.

*Upholstered main body with antishock polycarbonate core.
Natural beech frame.
New classic grey fabric upholstery.*



2812 FN T3 25

Sgabello Natural Zebra pop