LOUNGE/MEETING/EXECUTIVE

BOTERO

mignon

DESIGNCOLLECTION



LOUNGE/MEETING/EXECUTIVE

BOTERO

mignon

ACT DESIGN

modello depositato
patent pending
model breveté
Geschütztes Modell

La nuova serie Botero Mignon nasce a completamento della serie Botero, arricchendo la famiglia con colori e nuovi elementi.

Con l'avvento di Botero Mignon l'insieme della proposta si valorizza, permettendo al progettista di gestire e ottimizzare al meglio gli spazi grazie alle tre dimensioni di seduta (poltrona Mignon, poltrona e divano Botero) oltre al pouf e anche grazie alle diverse forme dei tavolini di servizio (tonda, ovale, rettangolare e quadrata).

Alla diversificazione delle sedute si aggiunge la versatilità nella proposta delle strutture, disponibili in più colori, che permette alla famiglia Botero di mantenere un carattere ludico e informale, ed un posizionamento funzionale a varie tipologie di ambiente.

The new Botero Mignon series was created to complement the Botero series, adding colours and new elements to the family.

With the arrival of Botero Mignon, the whole range is enhanced, in turn making it easier for designers to manage and optimize spaces thanks to the three seat sizes (Mignon armchair, Botero armchair and sofa) plus the pouf, and to the different shapes of the occasional tables (round, oval, rectangular and square).

The versatility of the frames - available in a range of colours - supplements the diversified seating options and enables the Botero family to keep a playful and informal feel, and a positioning that works well in different environments.

La nouvelle série Botero Mignon est née pour compléter la série Botero, afin d'enrichir la famille avec ses couleurs et ses nouveaux éléments.

Depuis l'arrivée de Botero Mignon l'ensemble de l'offre prend toute sa valeur, en permettant au concepteur de gérer au mieux et d'optimiser les espaces grâce aux trois dimensions des sièges (fauteuil Mignon, fauteuil et canapé Botero) ainsi que le pouf, grâce aussi aux différentes formes des tables basses (ronde, ovale, rectangulaire et carrée).

A la variété des choix des sièges, il faut ajouter les différentes possibilités de structures, ce qui permet à la famille Botero de conserver un caractère ludique et décontracté, et de bien l'adapter à toutes sortes d'intérieur.

Die neue Reihe Botero Mignon ist als Ergänzung zur Reihe Botero gedacht und bereichert die Familie mit ihren Farben und neuen Elementen.

Botero Mignon wertet das Gesamtangebot auf und ermöglicht dem Planer, die Räume mit Hilfe der drei Sitzgrößen (Sessel Mignon, Sessel und Sofa Botero) und dem Hocker sowie der verschiedenen Formen der Beistelltische (rund, oval, rechteckig und quadratisch) optimal zu organisieren und zu gestalten.

Ergänzt werden die unterschiedlichen Sitze mit verschiedenen Arten von Gestellen in mehreren Farben. Auf diese Weise fügt sich die Familie Botero mit ihrem glänzenden und ungezwungenen Äußeren funktionell in verschiedene Ambiente ein.



BOTERO MIGNON: EVERYDAY, EVERYWHERE.

BOTERO
mignon
LOUNGE

4/12



BOTERO
mignon
MEETING

8



BOTERO
mignon
EXECUTIVE
& VISITORS

20

BOTERO
mignon
COLORS

24







2.

1.



Mod. BM-004 + op. Mod. BM-MIX



Mod. BM-005



Mod. BM-001 + op. Mod. BM-MIX



Mod. BM-001 + op. Mod. BM-MIX



1.

4.



5.

2.

3.

1. Mod. BM-004 2. Mod. BM-003 3. Mod. BM-006 4. Mod. BM-005 5. Mod. BM-002

MEETING



1.



2.

MEETING



1.





Mod. BM-012 + op. Mod. BM-MIX



Mod. BM-016



1. Mod. BM-011 2. Mod. BM-071 3. Mod. BM-088

LOUNGE



1.

2.

3.

4.









Mod. BM-046



Mod. BM-032 + op. Mod. BM-MIX



Mod. BM-031 + op. Mod. BM-MIX

EXECUTIVE & VISITORS



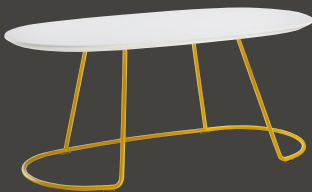









COLORS



BOTERO Mignon / 



Botero Mignon rappresenta il completamento della serie Botero.

La poltrona ha una sola dimensione ed è proposta in più tipologie di basi, strutture e colori (gli stessi di Blog e di Q3).

L'imbottitura di Botero Mignon è in Poliuretano schiumato a freddo, ignifugo autoestinguente in CL1, con formulazione "green" (utilizzo di materiale proveniente da riciclo al 30%) ed è composta da due elementi separati - sedile e schienale - uniti in fase di montaggio.

Il modello si presta per essere proposto con rivestimento bi-colore (codice BM-MIX), anche realizzato con rivestimenti di categorie diverse.

Botero Mignon è disponibile in più versioni con relative varianti:

versione fissa, con base a 4 gambe in legno massello di faggio naturale o in più colori laccati coprenti, oppure con base Skid in tondino d'acciaio Ø 12 mm in varie finiture e colori.

Versione girevole, con sedile elevabile, proposta con base Spider a 4 razze in più finiture e colori, oppure a 5 razze con ruote o piedini, mentre la versione girevole con base a 4 razze con piedini è disponibile con ritorno automatico della seduta "Torna".

I tavolini di servizio, compresi nella serie, sono di forma tonda, ovale, quadrata e rettangolare, e sono proposti con strutture in più finiture e colori in abbinamento a quelli della poltrona. Top in multistrati di betulla impiallacciato sulle due facce in laminato HPL da 0,9 mm (LAM) in più finiture o in MDF laccato in più colori.

Botero Mignon complements the Botero series.

The chair comes in a single size and a number of different bases, frames and colours (the same as Blog and Q3).

The padding for Botero Mignon is made from self-extinguishing, CL1 fire-retardant, cold-formed Polyurethane foam. This environmentally-friendly chair (using 30% recycled material) consists of two separate elements - seat and backrest - joined during assembly.

The model has provision for two-tone upholstery (code BM-MIX), which can also be made using different categories of upholstery.

Botero Mignon comes in several versions with corresponding variants:

fixed with 4-leg base in solid natural beech wood or in a range of covering matt lacquers, or with Skid base made from steel rod (Ø 12 mm) in various finishes and colours.

Swivel with 4-star Spider base in a range of finishes and colours, or 5-star Spider base with castors or glides; the cross base swivel version with glides is available with "Torna" automatic seat return.

The occasional tables comprised in the series are round, oval, square and rectangular, and their frames come in a range of finishes and colours to match the armchair. The tops are made from birch plywood, veneered on both sides with 0.9 mm HPL laminate (LAM) in a range of finishes or in lacquered MDF in a range of colours.

Botero Mignon représente le complément de la série Botero.

Le fauteuil a une seule dimension et il est proposé avec plusieurs types de piètements, de structures et de couleurs (les mêmes que Blog et Q3).

Le rembourrage de Botero Mignon est en mousse de polyuréthane injectée à froid, ignifuge et auto extinguable en Classe1, avec formulation écologique (emploi de matériaux recyclés à 30%) et est composé de deux éléments séparés - assise et dossier - assemblés en phase de montage.

Le modèle se prête bien à un revêtement bicolore (code BM-MIX), réalisé aussi avec des revêtements de catégories différentes.

Botero Mignon est disponible en plusieurs versions avec leurs variantes:

version fixe, avec 4 pieds en bois massif de hêtre naturel ou avec laquage couvrant en différentes couleurs, ou avec piètement luge en tube d'acier Ø 12 mm en différentes finitions et couleurs

Version tournante, réglable en hauteur, proposée avec piètement araignée à 4 branches en différentes finitions et couleurs, ou à 5 branches avec roulettes ou patins. La version tournante avec piètement à 4 branches avec patins est disponible avec retour automatique de l'assise "Torna".

Les tables basses, comprises dans la série, sont de forme ronde, ovale, carrée et rectangulaire, et sont proposées avec des structures en différentes finitions et couleurs, assorties à celles du fauteuil. Plateau en multiplis de bouleau plaqué sur les deux faces avec stratifié HPL de 0,9 mm (LAM) en plusieurs finitions ou en MDF laqué en différentes couleurs.

Botero Mignon ist die Ergänzung zur Reihe Botero.

Der Sessel wird in einer Größe und mit verschiedenen Arten von Gestellen und Farben angeboten (die gleichen wie Blog und Q3).

Die Polsterung von Botero Mignon ist aus PU-Kaltschaum, feuerfest und selbstverlöschend KL1, mit umweltfreundlicher Formel (zu 30% aus Recyclingmaterial) hergestellt und besteht aus zwei getrennten Teilen - Sitz und Rückenschale - die während der Montage miteinander verbunden werden.

Das Modell ist besonders mit dem zweifarbigen Bezug (Art.Nr. BM-MIX), der auch aus unterschiedlichen Kategorien zusammengesetzt werden kann, ein echter Blickfang.

Botero Mignon ist in verschiedenen Ausführungen mit den jeweiligen Varianten erhältlich:

Vierfußmodell aus massivem Buchenholz oder in mehreren Decklackfarben sowie mit Kufengestell aus Stahl-Rundrohr Ø 12 mm in verschiedenen Ausführungen und Farben.

Höhenverstellbarer Drehsessel mit 4-Stern-Fußkreuz in verschiedenen Ausführungen und Farben bzw. 5-Stern-Fußkreuz mit Gleitern oder Rädern, während der Drehsessel mit 4-Stern-Fußkreuz und Gleitern mit Rückholmechanik "Torna" erhältlich ist.

Die Beistelltische der Reihe sind rund, oval, quadratisch oder rechteckig. Die Gestelle stehen in mehreren Ausführungen und Farben, passend zu denen des Sessels, zur Verfügung. Tischplatte aus Birkenschichtholz, beidseitig beschichtet mit 0,9 mm HPL (LAM) in verschiedenen Ausführungen, oder aus MDF, in mehreren Farben lackiert.

 VARIANTI TAPPEZZERIA | UPHOLSTERY VARIANTS | VARIANTES TAPISSERIE | BEZUGVARIANTEN

**STANDARD**

Sedile, fronte schienale e retro schienale in un unico rivestimento.
 Seat, backrest front and backrest rear with a single upholstery.
 Assise, devant de dossier et arrière de dossier en un revêtement unique.
 Sitz sowie Rückenlehne vorne und hinten mit dem gleichen Bezug.

**op. BM-MIX**

Opzione schienale. Possibilità di scelta del retro schienale in altro colore dello stesso rivestimento oppure in rivestimento della stessa categoria (vedi listino).
 Backrest option. Possibility of choosing another colour of the same upholstery or upholstery from the same category (see price list) for the backrest rear.
 Option dossier. Possibilité de choisir pour l'arrière du dossier une autre couleur du même revêtement ou un revêtement de la même catégorie (voir catalogue).
 Option Rückenlehne. Für die Rückenlehne hinten Möglichkeit zur Wahl einer anderen Farbe des gleichen Bezugs oder eines Bezugs der gleichen Kategorie (siehe Preisliste).

 MECCANISMI E REGOLAZIONI | MECHANISMS AND ADJUSTMENTS | MÉCANISMES ET RÉGLAGES | MECHANIKEN UND FUNKTIONEN

**TORNA**

Ritorno automatico della seduta nella posizione iniziale.
 Automatic seat return to original position.
 Retour automatique de l'assise à sa position initiale.
 Rückholmechanik.

**A20G**

Elevazione della seduta con alzo a gas, comandato con leva.
 Lever-operated gas-lift for seat height adjustment.
 Réglage de la hauteur de l'assise avec vérin à gaz, commandé avec levier.
 Höhenverstellung mit Gaslift über seitlichen Hebel.

FINITURE PIANI/BORDI | TOP/EDGE FINISHES | FINITIONS PLATEAUX/CHANTS | AUSFÜHRUNGEN TISCHPLATTEN/KANTEN

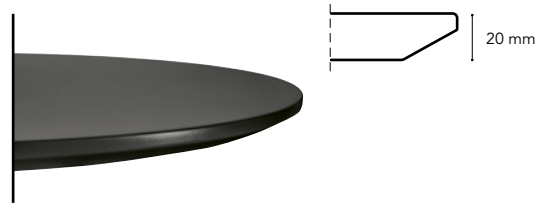
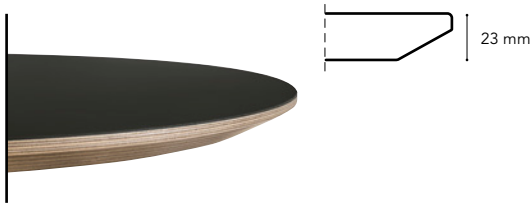

LAM

multistrati betulla 21 mm / laminato HPL 0,9 mm sulle due facce
21 mm birch plywood / 0.9 mm HPL laminate on both sides
Multiplis de bouleau 21 mm / stratifié HPL 0,9 mm sur les deux faces
Birkenschichtholz 21 mm / beidseitig beschichtet mit 0,9 mm HPL



N
nero
black
noir
Schwarz



BI
bianco
white
blanc
Weiß



RC2
rovere chiaro
light oak
chêne clair
Eiche hell

LAC

MDF 19 mm / laccatura coprente
19 mm MDF / covering lacquer
MDF 19 mm / laquage couvrant
MDF 19 mm / Decklackierung



LAC/NE



LAC/BI



LAC/AN



LAC/BL



LAC/GI



LAC/RO

FINITURE STRUTTURE | FRAME FINISHES | FINITIONS STRUCTURES | GESTELLAUSFÜHRUNGEN

STANDARD



N
nero
black
noir
Schwarz



CR
cromato
chromed
chromée
Chrom



BI
bianco
white
blanc
Weiß

COLOR



AN/75



BL/14



GI/32



RO/13

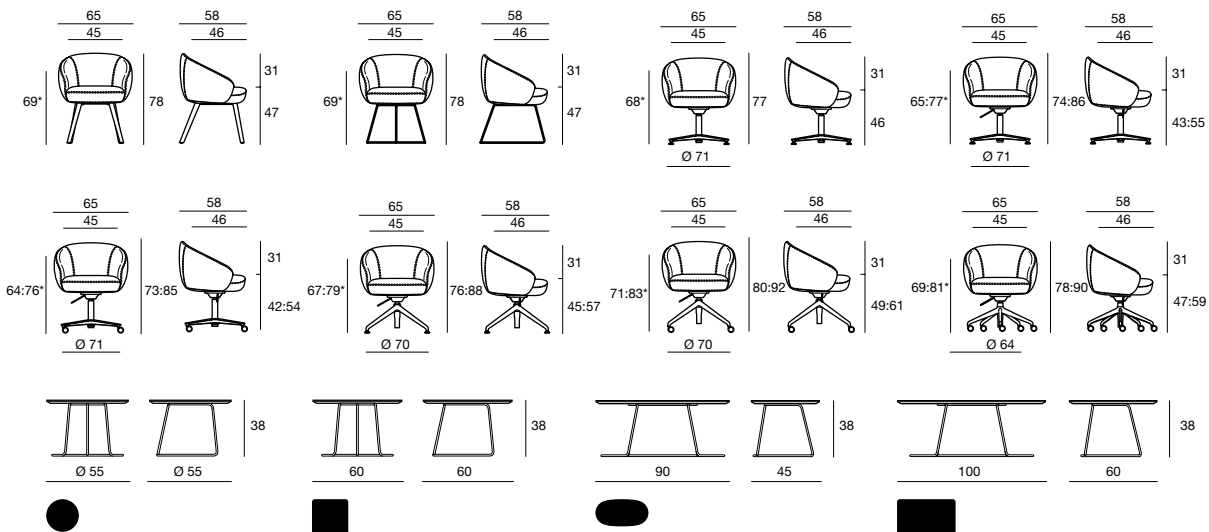

* Misura con sedia completamente abbassata, presa nella mezzera del bracciolo / Measured with seat completely lowered, taken in middle of the armrest
Mesure avec siège complètement baissé, prise dans la ligne médiane de l'accoudoir / Bei unterster Sitzhöhe, in der Mitte der Armlehne gemessen





STIMEX



Botero



BOTERO lounge / meeting

Serie di imbottiti composta da divano a 2 posti, poltrona fissa o girevole, pouf e tavolino di cortesia con piano fisso o ruotabile. Caratteristica peculiare di Botero oltre all'originalità del design, è l'elevato confort, dovuto ad un'imbottitura molto generosa, realizzata con l'applicazione di più strati di gomma poliuretana a densità differenziata, in abbinamento a cinghie elastiche poste sul sedile. Presentato al salone internazionale del mobile di Milano 2017 e pensato per una collocazione ludica ed informale, Botero ha ricevuto consensi per il gradevole valore estetico espresso dalle sue forme e per il piacere al contatto fisico, grazie alla sua invitante e morbida rotondità.

Padded furniture range composed of two-seater sofa, fixed or swivel armchair, low long stool and courtesy table with fixed or rotating top. In addition to its original design, Botero stands out for its extra comfort as a consequence of the very generous padding created by applying several layers of variable density Polyurethane foam, combined with elastic webbing on the seat. Showcased at the 2017 international furniture fair in Milan and designed with a playful, relaxed and informal setting in mind, Botero was met with approval due to the appealing aesthetic value of its forms and the pleasure of physical contact, thanks to its inviting, soft roundness.

Gamme de sièges rembourrés composée d'un canapé 2 places, d'un fauteuil fixe ou rotatif, d'un pouf et d'une table basse avec plateau fixe ou tournant. La caractéristique principale de Botero, outre l'originalité de son design, c'est son incomparable confort, dû à son rembourrage très généreux, réalisé en appliquant plusieurs couches de mousse de Polyuréthane à densité différenciée, associées aux sangles élastiques placées sur l'assise. Présenté au salon international du meuble de Milan 2017 et conçu pour une installation ludique et informelle, Botero a été apprécié pour l'agréable valeur esthétique qu'expriment ses formes et pour le plaisir de son contact physique auquel invite sa douce roondeur.

Die Polsterreihe besteht aus einem Zweisitzersofa, einem feststehenden oder drehbaren Sessel, einem Hocker und einem Beistelltisch mit fester oder drehbarer Platte. Die Besonderheit von Botero ist neben dem originalen Design der hohe Komfort, der durch die besonders großzügige Polsterung aus mehreren Schichten PU-Schaumstoff mit verschiedenen Dichten sowie die Sitzunterfederung mit Elastikgurtten gewährleistet wird. Auf der Mailänder Möbelmesse 2017 präsentiert, überzeugte das ungezwungene, fast spielerische Design von Botero mit der angenehmen Ästhetik seiner Formen und den weichen, einladenden Rundungen, die Lust auf Gemütlichkeit machen.

ACT DESIGN



BOTERO



lounge/meeting.



BOTERO



lounge/meeting.



BOTERO



lounge/meeting.



BOTERO



lounge/meeting.



BOTERO



lounge/meeting.



BOTERO





lounge/meeting.

BOTERO

Serie composta da poltrona, poltrona girevole, divano a due posti, pouf e tavolino. Confort elevato assicurato dai vari strati di gomma a densità differenziata che formano l'imbottito, e dalle cinghie elastiche sul sedile. Struttura portante in parti assemblate di multistrato di conifera e abete spessore 18 mm. Rivestimento della struttura lignea con pannelli sagomati di faesite da 2,5 mm. Poltrona girevole con base piana d'acciaio da Ø 540 mm, spessore 8 mm; versione fissa invece dotata di piedini regolabili (15 mm). Poltrona e divano sono rivestiti con fodere distinte: una per il sedile ed una per lo schienale; pouf rivestito con un'unica fodera fissata sotto la base della seduta. Botero è disponibile in tutti i rivestimenti a cartella a esclusione di: Leder, Leder Vega, Skai Flo, Country, Radio, Architecture.

TAVOLI DI CORTESIA – i tavoli hanno il piano fisso o ruotabile a 360°, entrambi di forma ellittica 780x570 mm; top in MDF laccato opaco bianco (RAL 9010) o antracite (RAL 7005). Lo stesso può essere rivestito in pelle in abbinamento al divano (fintapelle e tessuto non disponibili). Struttura portante composta da colonna Ø 50 mm con base piana di forma ellittica 680x500 mm, spessore 8 mm. Finiture: struttura bianca (RAL 9010) o cromata con copertura in acciaio inossidabile.

Range composed of armchair, swivel armchair, two-seater sofa, low long stool and side table. High level of comfort assured by the different layers of variable density Polyurethane foam padding and by the elastic webbing on the seat. Framework in assembled parts of 18 mm thick fir and spruce plywood. Wooden frame clad in 2.5 mm thick, shaped hardboard panels. Swivel armchair comes with a Ø 540 mm, 8 mm thick flat steel base; the fixed version is fitted with adjustable levers (15 mm). Armchair and sofa are upholstered with separate covers: one for the seat and one for the backrest; low long stool covered with a single fixed cover under the seat base. Botero is available in all standard coverings except Leder, Leder Vega, Skai Flo, Country, Radio and Architecture.

COURTESY TABLES – the tables have a fixed top or 360° rotating top, both elliptical (780x570 mm); top in matte white (RAL 9010) or anthracite (RAL 7005) lacquered MDF. This can also be covered in leather to match the sofa (faux leather and fabric not available). Framework composed of Ø 50 mm column with flat, 8 mm thick elliptical shaped base (680x500 mm). Finishes: white (RAL 9010) or chrome finish with stainless steel cover.

Série composée d'un fauteuil, d'un fauteuil tournant, d'un canapé deux places, d'un pouf et d'une table basse. Confort élevé assuré par plusieurs couches de mousse de Polyuréthane à densité différenciée qui forment le rembourrage, et par les sangles élastiques sur l'assise. Structure portante en bois avec panneaux profilés d'isorel de 2,5 mm. Fauteuil tournant avec socle plat en acier Ø 540 mm, épaisseur 8 mm; version fixe munie de patins réglables (15 mm). Le fauteuil et le canapé sont revêtus de housses différentes: une pour l'assise et une pour le dossier; pouf revêtu d'une seule housse fixée sous la base du siège. Botero est disponible avec tous les revêtements du catalogue excepté: Leder, Leder Vega, Skai Flo, Country, Radio, Architecture.

TABLES DE SERVICE – les tables ont le plateau fixe ou tournant à 360°, toutes les deux de forme elliptique 780x570 mm; plateau en MDF laqué mat blanc (RAL 9010) ou anthracite (RAL 7005). Celui-ci peut aussi être revêtu en cuir assorti au canapé (simili cuir et tissu non disponibles). Structure portante composée d'une colonne Ø 50 mm avec socle plat elliptique 680x500 mm, épaisseur 8 mm. Finitions: structure blanche (RAL 9010) ou chromée avec couverture en acier inoxydable.

Die Reihe besteht aus Sessel, Drehsessel, Zweisitzersofa, Hocker und Beistelltisch. Der hohe Komfort wird durch die Polsterung aus mehreren Schichten PU-Schaumstoff mit verschiedenen Dichten sowie die Sitzunterfederung mit Elastikgurten gewährleistet. Das tragende Gestell setzt sich aus mehreren 18 mm starken Koniferen- und Tannen-Schichtholzteilen zusammen. Beschichtet ist das Gestell mit 2,5 mm starken geformten Pressholzplatten. Der Drehsessel hat einen 8 mm starken Stahlsteller Ø 540 mm, während die feststehende Ausführung verstellbare Gleiter (15 mm) besitzt. Sessel und Sofa haben zwei getrennte Bezüge, je einen für Sitz und Rückenlehne. Der beim Hocker unter der Sitzfläche befestigte Bezug ist dagegen einteilig. Botero kann mit den Bezügen der Standardkollektion bezogen werden. Ausgenommen sind die Bezüge Leder, Leder Vega, Skai Flo, Country, Radio, Architecture.

BEISTELLTISCHE – Die Tische haben eine feste oder um 360° drehbare Platte, beide Ausführungen sind ellipsenförmig 780x570 mm und bestehen aus einer matt lackierten MDF-Platte in weiß (RAL 9010) oder anthrazit (RAL 7005). Sie ist auch passend zum Sofa bezogen lieferbar (Stoff und Kunstleder nicht erhältlich). Das tragende Gestell besteht aus einer Säule Ø 50 mm mit einem 8 mm starken, elliptischen Fußteller 680x500 mm. Ausführungen: Gestell weiß (RAL 9010) oder verchromt mit Edelstahl überzogen.

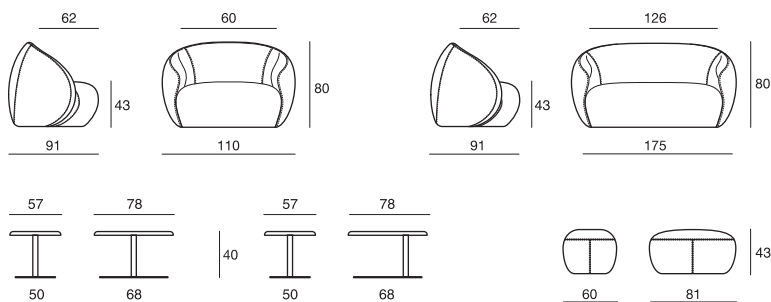

Piano tavolino | Coffee table top | Plateau table | Tischplatte



BT-016 Fisso
Fixed
Fixe
Fest

BT-011 Girevole a 360°
Swivel (360°)
Tourmant à 360°
Drehbar um 360°

Finitura piano | Table top finishing | Finition plateau | Plattenausführung



LA/75 laccato opaco antracite
matte anthracite lacquer
Laqué mat anthracite
anthrazit matt lackiert

LA/10 laccato opaco bianco
matte white lacquer
Laqué mat blanc
weiß matt lackiert

GPL/E/LUX pelle
leather
cuir
Leder

Finiture struttura | Frame finishes | Finition structure | Gestellausführung



BI10 colonna e base bianche
white column and base
colonne et socle blancs
Säule und Bodenteller weiß

CR colonna cromata / base inox
chrome column / stainless steel base
colonne chromée / socle inox
Säule verchromt / Bodenteller Edelstahl

Cuscino | Pillow | Coussin | Kissen



Op. BT-021

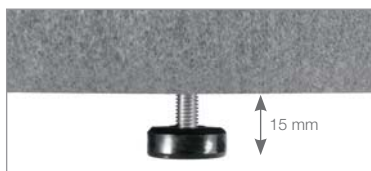

Piedino regolabile
Adjustable leveller
Patin réglable
Verstellbarer Gleiter



Piastra girevole a 360°
Swivel plate (360°)
Plaque tournante à 360°
Drehteller 360°

Variante tappezzeria | Upholstery version | Variante tapisserie | Bezugvariante



Op. E/MIX

Variante con fronte in pelle Florida o Toscana (cat. LUX) e retro in tessuto Lanee / Lanee Melange (cat. D) o Mood (cat. GPL). La combinazione dei due rivestimenti è da considerarsi, ai fini del prezzo, in Cat. E.

Version with Florida or Toscana leather front (LUX) and Lanee / Lanee Melange fabric back (D) or Mood back (cat. GPL). For pricing purposes, the combination of the two coverings is to be considered in Cat. E.

Variante avec devant en cuir Florida ou Toscana (cat. LUX) et rétro en tissu Lanee / Lanee Melange (cat. D) ou Mood (cat. GPL). La combinaison des deux revêtements est à considérer, pour le prix, en Cat. E.

Variante mit Frontseite aus Leder Florida oder Toscana (Kat. LUX) und Rückseite aus Stoff Lanee / Lanee Melange (Kat. D) oder Mood (Kat. GPL). Die Kombination der beiden Bezüge gehört zur Preiskategorie E.

Nuovi rivestimenti presenti in questo catalogo | New coverings listed in this catalogue | Nouveaux revêtements présents dans ce catalogue | Neue Bezüge, die mit diesem Katalog in die Kollektion einfließen

Rivestimenti | Upholstery | Revêtements | Stoffbezug

Cat. GPL
MOOD "OD"

92% NZL wool - 8% PA polyamide



OD11 grigio
grey
gris
Grau



OD14 arancio
orange
orange
Orange

Pelli | Leather | Cuirs | Leder

Cat. LUX

TUSCANIA "TU" Vera Pelle vintage | Real vintage leather | Vrai cuir vintage | Echtes Antikleder
Spessore | Thickness | Epaisseur | Stärke 0,8 - 1,0 mm



TU22 biscotto



TU21 cobblestone



TU24 dark brown



TU27 blackwood

Fuori cartella | Out of card | Hors catalogue | Außerhalb der Mustermappe

Pelle Nabuk creta | Clay Nubuck leather | Cuir Nubuck crète | Nubukleder tonfarben

